

University of Central Florida

College of Engineering and Computer Science

Department of Electrical and Computer Engineering



Project Document

Portable PCR Diagnostics

**A convenient portable diagnostics system for quantitative viral detection
with wireless capabilities**

Group 11:

Marc Burrell - EE/CPE

Mario Martinez - EE

Geoffrey Mulberry - EE

Sponsored by:

Dr. Brian N. Kim

Date Submitted: 8/1/2017

Project Term: Summer 2017

Course Instructor: Lei Wei

Table of Contents

Table of Contents	i
Table of Figures	vi
Table of Tables	vii
1 Executive Summary	1
2 Product Description	2
2.1 Motivation	2
2.2 Objectives	3
2.3 Requirements Specifications	5
2.4 House of Quality	5
2.5 Possible Block Diagram	7
2.6 Deliverables	8
2.6.1 Marc Burrell	8
2.6.2 Mario Martinez	9
2.6.3 Geoffrey Mulberry	9
3 Research Related to Project Definition	11
3.1 Existing Similar Projects and Products	11
3.1.1 Commercial Products	11
3.1.1.1 Applied Biosystems 7900HT Fast Real-Time PCR System	11
3.1.1.2 miniPCR	12
3.1.2 Research Projects	13
3.1.2.1 Cylindrical PCR	13
3.1.2.2 Portable PCR	14
3.2 Relevant Technologies	14
3.2.1 Joule Heating	15
3.3.7 Thin Film Transistor Liquid Crystal Display	15
3.2.2 Thermistor	16
3.2.3 Inter-integrated Circuit Protocol (I2C)	17
3.2.4 Serial Peripheral Interface (SPI)	19
3.2.5 PID	20
3.2.6 Universal Asynchronous Receiver/Transmitter (UART)	23
3.2.7 Position Tracking	25
3.2.7.1 Global Positioning System (GPS)	26

3.2.7.2	GLONASS	27
3.2.7.3	Android Location Services	28
3.2.7.4	Decision	29
3.2.8	Pulse Width Modulation (PWM)	30
3.2.9	Optical Components	31
3.2.9.1	Photodiodes	31
3.2.9.2	Light Emitting Diodes (LED)	32
3.2.9.3	Optical Filters	32
3.2.10	Wireless Communications	32
3.2.10.1	Bluetooth	33
3.2.10.2	Infrared	35
3.2.10.3	Zigbee	36
3.2.10.4	Technology Decision	37
3.2.11	Operational Amplifier	39
3.2.12	Touch Screens	40
3.2.12.1	Capacitive Touch Screens	40
3.2.12.2	Resistive Touch screens	41
3.2.12.3	Decision	42
3.3	Strategic Component and Part Selections	42
3.3.1	Position Tracking	42
3.3.1.1	Decision	43
3.3.2	Operational Amplifier	43
3.3.2.1	Decision	44
3.3.3	MOSFET	45
3.3.3.1	Decision	45
3.3.4	Temperature Reading Components	46
3.3.4.1	Thermocouple	46
3.3.4.2	Thermistor	47
3.3.4.3	Resistive Temperature Detectors	48
3.3.4.4	Decision	48
3.3.5	Power Sources	50
3.3.5.1	Decision	52
3.3.6	Microcontrollers	52
3.3.6.1	ATmega2560	52
3.3.6.2	TI CC2640	53

3.3.6.3 Microchip PIC24FJ32MC104	53
3.3.6.4 Decision	53
3.3.8 Wireless Communication	54
3.3.8.1 Decision	55
3.3.9 Photodiodes	56
3.3.9.1 Decision	56
3.3.10 LEDs	57
3.3.10.1 Decision	57
3.3.11 Servomotors	58
3.3.11.1 Decision	58
3.3.12 Display Screens	58
3.3.12.1 Adafruit 2.8" TFT Touch Shield v2	58
3.3.12.2 Adafruit with Capacitive Touch	59
3.3.12.3 Adafruit 2.8" TFT LCD B/O Board w/microSD	59
3.3.12.4 Decision	60
3.4 Parts Selection Summary	60
4 Related Standards and Realistic Design Constraints	63
4.1 Standards	63
4.1.1 Health Insurance Portability and Accountability Act (HIPAA) Compliance	63
4.1.2 IP Standard	64
4.1.3 FR-4 PCB	64
4.2 Realistic Design Constraints	66
4.2.1 Economic and Time Constraints	66
4.2.2 Environmental, Social, and Political Constraints	68
4.2.3 Ethical, Health, and Safety Constraints	70
4.2.4 Manufacturability and Sustainability Constraints	70
5 Project Hardware and Software Design Details	72
5.1 Heating and Cooling	72
5.1.1 Heating Element Design	72
5.2 Optical Design	75
5.2.1 Origin of Fluorescent Signal	76
5.2.2 Light Source, Detection, and Filters	77
5.3 Software	78
5.3.1 Main Control	79

5.3.2 MCU	80
5.3.3 Embedded Software	81
5.3.3.1 Responsibilities	81
5.3.3.2 Language	83
5.3.4 Android Application	83
5.3.4.1 Programming Language	83
5.3.4.2 Software Development Kit and Libraries	84
5.3.4.3 Integrated Development Environment	84
5.3.4.4 Application Structure	84
5.3.5 Online Databases	86
5.3.5.1 TinyWebDB	86
5.3.5.2 FirebaseDB	87
5.3.5.3 Fusion Tables	87
5.6 Power Systems	89
5.6.1 Switch Mode Power Supply	89
5.6.1.1 Decision	91
5.6.2 Charging	92
5.7 User Interface	93
5.7.1 User Selection and Navigation	93
5.7.1.1 Push Buttons	94
5.8 Mechanical System Design	95
5.8.1 Servo Motors	98
5.9 Component Interface Design	99
5.9.1 Bluetooth Interface Design	99
5.9.2 Thin Film Transistor Liquid Crystal Display Interface Design	100
5.10 Breadboard Testing	102
5.10.1 Touchscreen Display Testing	102
5.10.2 GPS Module Testing	103
5.10.3 Bluetooth Module Testing	103
6 Project Prototype Construction	105
6.1 Construction of Aluminum Heating Block	105
6.2 3D Printing of Parts	106
6.3 PCB Construction	106
7 Project Prototype Testing and Plan	109
7.1 Design and Prototype Testing	109

7.1.1 Thermal Design Testing	109
7.1.2 Impact Testing	111
7.2 Software Testing	111
7.2.1 Simulated Testing	112
7.2.1.1 Microcontroller Software	112
7.2.1.2 Mobile Application	112
7.2.2 Physical Testing	113
7.3 Final Device Testing Plan and Goals	113
7.3.1 PCR Testing	113
7.3.2 Sample Preparation	115
7.3.2.1 Sample Preparation Procedure	117
8 Administrative Content	119
8.1 Timeline and Milestones	119
8.2 Budget and Finance Discussion	120
8.3 Sponsorship	120
Appendix	122

Table of Figures

Figure 2.1	6
Figure 2.2	7
Figure 3.1	11
Figure 3.2	12
Figure 3.3	13
Figure 3.4	14
Figure 3.5	16
Figure 3.6	17
Figure 3.7	17
Figure 3.8	18
Figure 3.9	19
Figure 3.10	19
Figure 3.11	20
Figure 3.12	21
Figure 3.13	22
Figure 3.14	23
Figure 3.15	23
Figure 3.16	24
Figure 3.17	25
Figure 3.18	26
Figure 3.19	27
Figure 3.20	28
Figure 3.21	30
Figure 3.22	36
Figure 3.23	37
Figure 3.24	39
Figure 3.25	41
Figure 3.26	41
Figure 3.27	44
Figure 3.28	45
Figure 3.29	51
Figure 3.30	61
Figure 4.1	66
Figure 4.2	69
Figure 4.3	71
Figure 5.1	73
Figure 5.2	74
Figure 5.3	74

Figure 5.4	75
Figure 5.5	76
Figure 5.6	77
Figure 5.7	78
Figure 5.8	82
Figure 5.9	82
Figure 5.10	85
Figure 5.11	87
Figure 5.12	88
Figure 5.13	89
Figure 5.14	89
Figure 5.15	90
Figure 5.16	91
Figure 5.17	93
Figure 5.18	94
Figure 5.19	95
Figure 5.20	96
Figure 5.21	97
Figure 5.22	98
Figure 5.23	100
Figure 5.24	101
Figure 5.25	102
Figure 5.26	103
Figure 5.27	104
Figure 6.1	105
Figure 6.2	106
Figure 6.3	107
Figure 6.4	107
Figure 6.5	108
Figure 7.1	110
Figure 7.2	111
Figure 7.3	114
Figure 7.4	116
Figure 8.1	119

Table of Tables

Table 2.1	5
Table 3.1	31
Table 3.2	35
Table 3.3	38
Table 3.4	42
Table 3.5	44
Table 3.6	46
Table 3.7	49
Table 3.8	49
Table 3.9	50
Table 3.10	51
Table 3.11	54
Table 3.12	55
Table 3.13	56
Table 3.14	57
Table 3.15	58
Table 3.16	59
Table 3.17	62
Table 4.1	65
Table 4.2	65
Table 5.1	80
Table 5.2	91
Table 5.3	92
Table 5.4	99
Table 5.5	101
Table 7.1	115
Table 8.1	120

1 Executive Summary

In the field of medical diagnostics, polymerase chain reaction (PCR) is a technique used to amplify a specific section of DNA. This process that generates millions to trillions of copies of the target DNA or gene, usually from a specific virus being tested for, such as HIV. Since developed in the 1980s it has changed the face of biology, for its applications are vast and has not yet reached its full potential. Common work done using PCR include DNA and gene detecting, paternity testing, forensics, genotyping, cloning, and mutation detection. PCR is important to molecular biology because the quantity of DNA in a given sample typically isn't enough to run tests, as the detection equipment is not sensitive enough.

The process of PCR relies on the thermal cycling of a sample between approximately 60 and 95 degrees Celsius. When the sample is at 95 degrees, the DNA in the sample is split into its two strands. The sample is then cooled to 60 degrees where the polymerase in the sample begins to reconstruct the opposite half of the DNA strands, the entire thermal cycle results in a doubling of the quantity of DNA in the sample. When repeating this thermal cycle 40 times, the amount of DNA in the sample effectively increases 2^{40} times. This amplification is the means by which PCR has become the industry standard in viral detection because it allows for the easy detection of the virus concentration. For example, if there is one segment of HIV virus DNA in the sample at the beginning of the process, there will be more than one trillion copies of that DNA at the end. This massive quantity of DNA at the end of the process is much more easily detected than a single segment and the primary reason PCR has become the industry standard.

The detection method usually relies on some form of optical detection. These methods rely on some form of primer which mates to a specific sequence of DNA. When bonded to DNA, this primer fluoresces if excited by a particular wavelength of light and emits light on another wavelength. In physical implementations of a fluorescent detection system, the sample is excited by an LED or laser usually passed through an optical bandpass filter. This is so the excitation occurs on the exact wavelength required by the specific primer. The system then observes the sample using a photodiode or similar detector behind another optical bandpass filter centered on the specific wavelength emitted by the primer. Since the primer will only bond to a specific sequence of DNA, a PCR system equipped with a fluorescent detection system can be extremely sensitive at measuring very specific target DNA. Since the primers can be designed to bond to any sequence of DNA, a primer can be made that will bond to a sequence only found in a virus, such as HIV. Using this feature, a PCR device can be made to search for and detect any virus present in a sample, thus allowing for accurate diagnosis patient.

2 Product Description

A Portable PCR machine will make research far better for those areas around the world that have limited access to PCR machines or are in short supply. The convenience of its size and test rate will make our design very appealing.

This section contains:

- Our motivation for making a portable PCR machine and the need that appears to be addressed
- The objectives that we are trying to meet and why they are important to the project

2.1 Motivation

PCR being the key player that it is for molecular biology makes producing a portable PCR machine very appealing. Currently the PCR machines today are large in size and very expensive. This group desires to produce a device that is the contrary; small, cheap, and portable. The portability feature by itself, allows for a great impact on the science community and, indirectly, to the world. Being portable, more research can be done around the world. Scientists and forensics don't have the privileges of taking their work or their lab where they need to, since most of their equipment is large and too expensive to risk damaging. For this reason, much of the testing process is delayed, which could have dramatic consequences for individuals with diseases. With a portable device, fast test results would greatly increase and more data from around the world would be acquired, allowing for doctors to better plan strategies for treating disease outbreaks.

Outbreaks are a main focus to molecular biologists and a world concern when they occur. There have been countless times in the United States that an outbreak has caught the attention and stimulated fear of the citizens. Examples such as the Zika virus, Ebola virus, and H1N1 virus are well known. When the United States heard reported cases of the Zika virus in Miami, studies ensued. A portable PCR machine would have been perfect for this situation. Scientists in the area, and many others sent to do studies on the situation, would have the ability to test patients who are suspected of having the virus in a quick manner. Currently the processes is slow. Scientists take samples from the patients then send them to the lab for evaluation. Since a scare is in a specific location, there are a finite number of PCR machines also in that area. Samples must wait to be tested or

sent elsewhere, which also hinders results. For any outbreak minimum delay is crucial. Although our device is capable of running a PCR in a normal operation, our design is specific to viral detection. With quantitative viral detection, our PCR machine will give results to the presence of the virus immediately after running the PCR. Most PCR machines today do not have viral detection and require additional equipment and additional steps to yield those results. Scientists can avoid these hiccups with a portable quantitative PCR device that we are proposing. The device will provide quick results, which allows for more data to be collected over a shorter period of time, reducing risks of the virus spreading.

Global research is also a focus of ours for designing our project. There are many countries to this day that are very poor or underfunded and their citizens are suffering from diseases. We would like for either those countries themselves to be able to afford a PCR machine so they can conduct their own research and take action according to their data, or for scientists from around the world to be able to travel to these areas with a device that is cheap and portable. Therefore we are designing our project with expenses in mind, we want the device to be far cheaper than current PCR machines on the market, which vary from a thousand dollars to several thousand dollars. With our goal of limiting its cost, we envision the device being able to be produced in many areas in the world.

As one can see, having a portable PCR machine is beneficial in many ways. Therefore our design focuses on being convenient for travel. Our design will run on rechargeable batteries, and can run many tests before needing to recharge. In addition, our device will have the ability to wirelessly connect to a smartphone and have an app available to interact with the device. This will make the device easier to use by providing an interface most people are already familiar with and allows the device to be smaller, which improves its portability. One of the best features our design has to offer is its quantitative viral detection. As mentioned, the majority of PCR machines do not provide quantitative viral detection, and given the situation where third world countries are in need of testing or a viral outbreak occurs, our design would provide the instant feedback desired without the need for additional devices and extra procedures because third world countries can't afford them and, unfortunately, outbreaks do not wait.

2.2 Objectives

The primary objective of this project is to create a smaller, faster, more efficient Polymerase Chain Reaction (PCR) machine than what is currently commercially available and most widely used. We aim to build a complete product with sufficient hardware and supporting software to, as accurately as possible, detect the presence of specific blood borne viruses such as malaria, HIV, and more. The

device should be able to successfully heat a sample of blood and examine it to provide information on the concentration of the desired DNA in the sample. Another primary feature we are aiming for is portability, creating the smallest device possible and including compatibility with mobile phones to externally process information. We want to be able to ultimately collect large amounts of data in order to make available maps and observable trends of viruses from anywhere for further study. These features should ease the current process of sending samples to the closest available medical facility for a few days to be processed, often at locations very far from the patient. We also want to make this product readily available, keeping the materials used to make the product simple, easy to access, and not very expensive as to make it easily available to even the most remote areas of the world. We are being sponsored but to achieve this we will try to keep the final budget as small as possible to maximize availability and efficiency. The project should be finished by the end of EEL 4915 Senior Design II in August of 2017.

Hardware

The hardware included will consist of the materials necessary to complete the basic functions of the PCR machine. The main components of the machine will be two heating elements, two temperature detection devices, two small motors, a photodiode, LEDs, optical filters, a location module, wireless transmitter, a display, 3D printed frame and small parts, and a microcontroller to coordinate it all with a simple user interface.

Software

The software will consist of a main program flow to carry out a testing of a sample and a few functions to deal with user input and data processing. There will also be external software development in the form of a mobile app and online database to further process and store data. The software should be able to read, calculate, and represent the data accurately, display the information, and record it ideally indicating whether or not the virus is present in the current sample.

Connection

The PCR machine will communicate with a few outside sources wirelessly to achieve the goals for our design. Each component will communicate with the microcontroller to process data and control the machine or provide data remotely (determining location, giving specific settings etc.).

Interface

The PCR machine will have at least two options for user interface and control, local and external. Local will include input devices on the module to control the process directly. External controls will be optional to control the module remotely.

Control

The controls will be very simple, having the microcontrollers processes control most of the action automatically. Users can simply input settings and press start and cancel at any point. The microcontroller will process data to control the entire process based on the input uninterrupted.

2.3 Requirements Specifications

To keep the design process on track, it is necessary to create a concise list of specifications that the group would like to meet. This list is included in the table below.

2.4 House of Quality

To further help develop our design, we have constructed a matrix consisting of marketing requirements and engineering requirements as shown in Figure 2.1. The matrix allows us to understand the relationships between both engineering requirements and marketing requirements, while also relating the engineering requirements individually with one another. With these comparisons, the matrix represents how our design correlates to customer needs.

Heating and Cooling:	Must heat up to 95C and cool to 60C
Location:	Using GPS must be able to determine location +/- 100m accuracy
Wireless Communication:	Must be able to transmit all data via wireless technology to a mobile device (WiFi, Bluetooth, ect.)
Optical Filtering:	Detecting 518 nm wavelength
Weight:	< 7.5 lbs
Cost:	< \$500
App integration:	Must relay data to the app, display its results, and be controlled by the app
Dimensions:	< 64 inches squared

Table 2.1: specifications for the device

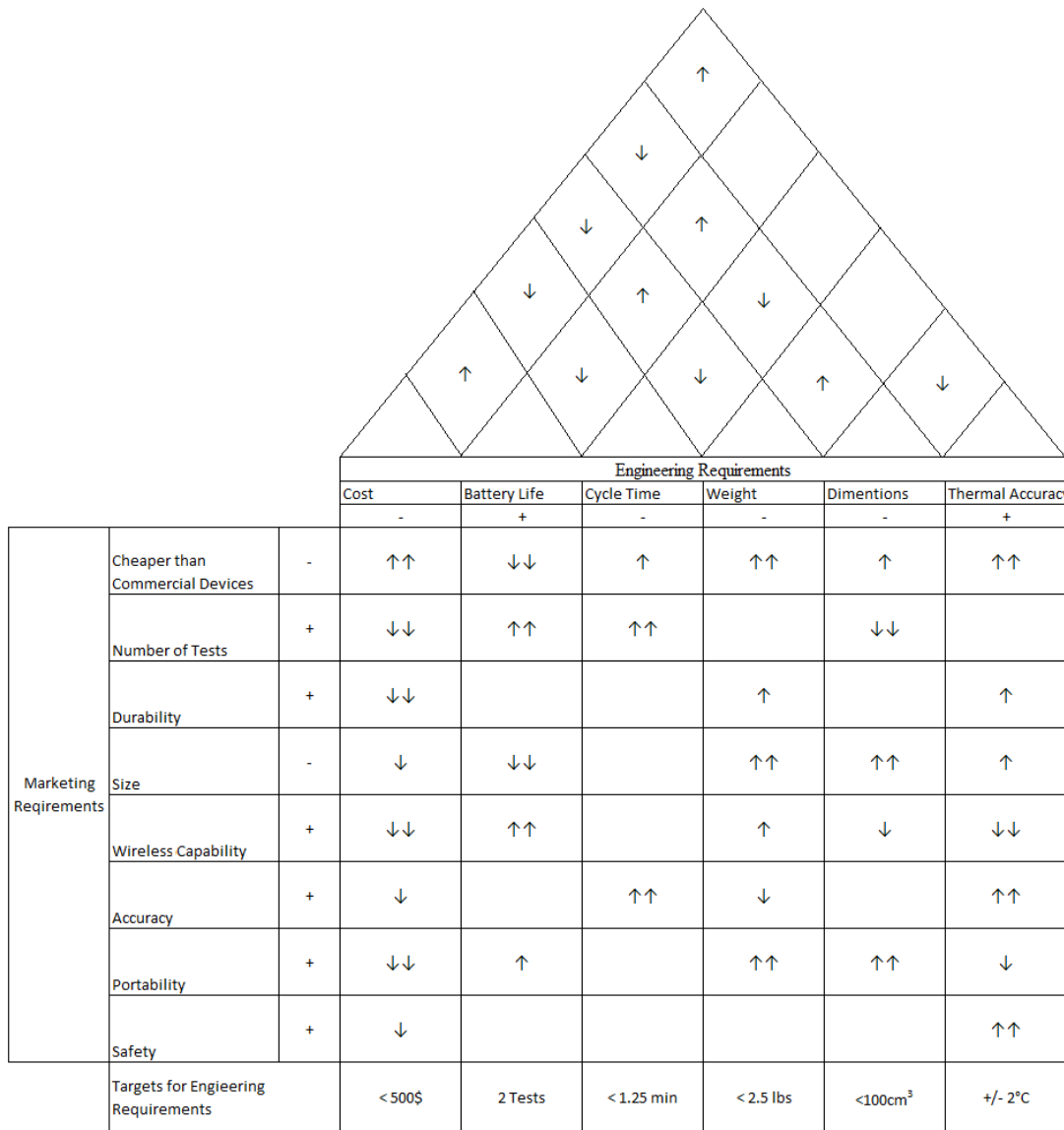

Figure 2.1: The house of quality, for comparing specifications

Key

- + = Positive polarity, Increasing the Requirement
- = Negative Polarity, Decreasing the Requirement
- ↑ = Positive correlation
- ↑↑ = Strong positive correlation
- ↓ = Negative correlation
- ↓↓ = Strong negative correlation

2.5 Block Diagram

Portable PCR Diagnostics Functional Block Diagram

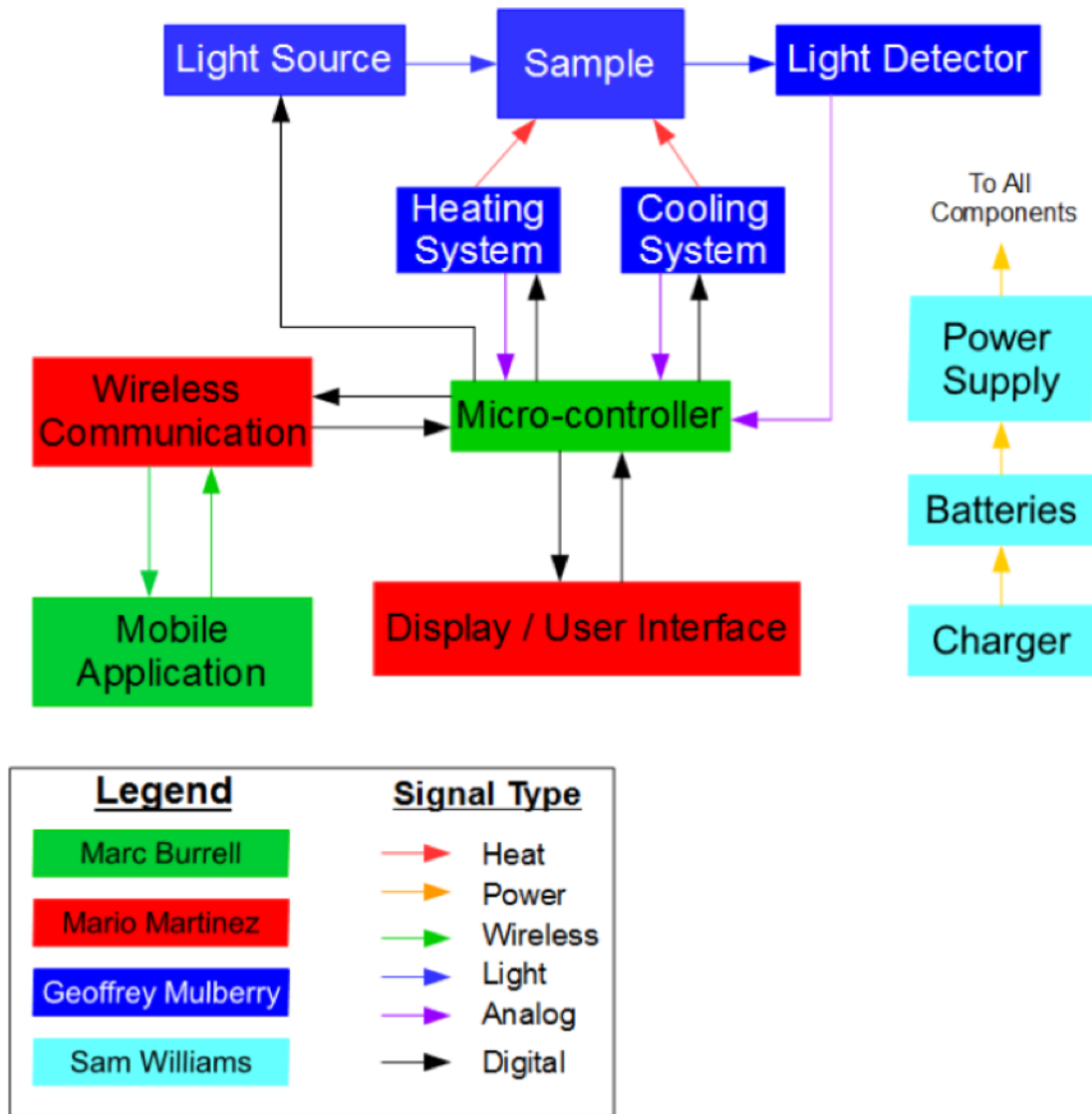

Figure 2.2: Block diagram showing connections between all elements and the group members responsible for them. Sam Williams left our group and his portion of the project has been divided among the three members.

The proposed system consists of the above elements. The main component of the device is the sample, which contains (or does not contain) the virus being detected. Two systems, the heating and cooling systems are controlled by the microcontroller and are responsible for the transfer of heat into and out of the sample to facilitate thermocycling, which is required PCR. The light source and light detector, work together to determine the concentration of target DNA in the

sample. This data is recorded by the microcontroller and sent to the mobile application for additional processing via the wireless communication system. The system also consists of a display and user interface so that the device is still functional without the use of a mobile phone.

2.6 Deliverables

Each team member is tasked with a specific and vital portion of this project. In order to keep the team on track throughout the duration of the project, each team member's responsibilities and goals are outlined in the following section.

2.6.1 Marc Burrell

Marc Burrell will be mainly responsible for the external software and related material since he is the computer engineer of the project group. He will be fully responsible for developing the mobile application's set up, design, flow, overall programming, and execution. Of course, the team as a whole will assist with streamlining the design to help integrate it best with the system as a whole and provide ideas for features and overall flow. Marc will be responsible for implementing the ideas and making sure the mobile application works seamlessly with the stand alone PCR machine, managing construction of the code in the microcontroller as well to work efficiently while connected wirelessly to the mobile device. He will be responsible for research determining which mobile application would work best with the PCR machine, how to achieve the goals set for the project functionality, and deciding the best way to efficiently implement the features of the external use of the PRC machine. He will also be responsible for setting up an online database to showcase the goal of taking data from a sample and adding it to a larger grouping of data from other tests taken directly from the mobile application. He will ensure the database achieves the goal of allowing researchers and medical professionals to easily visualize and compile data based on different information to efficiently make inferences about each disease represented.

Along with external software development, Marc's role in initial research included helping determine which Microcontroller and which heat sensing technique to use. He is responsible for determining which microcontroller will be able to best fit the requirements of the system fully and eventually most efficiently. This task is actually more inclusive of the whole team, as the microcontroller interacts with every part of the entire machine. Each teammate will need to be consulted for compatibility with their part decisions and potential ideas on which one to go with. Marc will be responsible for ensuring that the final code on the microcontroller runs seamlessly as well, achieving every desired outcome and functionality. As

for the heat readings, Marc will find the best, smallest, most efficient way to quickly read the temperature and use this information to assist the heating process. Most likely researching quick electrical techniques used to measure an instantaneous temperature reading and use it as feedback to help control the heating control system.

2.6.2 Mario Martinez

Mario Martinez's contribution to the design is based upon the communication technologies the device will have integrated and the user interface. The device although portable will have many features that will operate autonomously and have capabilities to operate with other devices. Mario will implement the wireless communication system onto the portable PCR machine. He will manage this system, assuring that the portable PCR machine will be able to send data and the proper packets to and from the device. He will investigate all the possible technologies and select the best suited technology available to install on the design. Mario will assure that the communication device will be reliable, in that our device will be able to communicate with other devices such as a smartphone when prompted to. Mario will optimize the wireless communications by minimizing any delays to provide a better experience for the user and by also maximizing the speed at which data is transferred. Mario will also pay close attention to the distance wireless communication the device will be able to perform from. Mario will have the responsibility of both the wireless communication between two devices and the position tracking technology.

Mario will also be the administrator to the user interface. Mario will select the proper display for the device as well as the the proper user interaction technology. The user interaction technology will be the components that allow the user to make selections on the device, such as buttons and a touchscreen. Mario will determine the best size, location, and quantity of the user interaction components for the portable PCR machine. He will assure that device will be user friendly and will operate as the device is commanded to without error.

2.6.3 Geoffrey Mulberry

Geoffrey Mulberry's main area of responsibility lies with the design of two of the main systems for the PCR machine: the mechanical system, and the optical system. For the mechanical system, Geoffrey will be responsible for sourcing all of the components for the electronic heating and cooling operations, as well as the motors that will be used to move the various mechanical parts. Geoffrey's experience with mechanical design, 3D modelling, and 3D printing will be used to its full extent throughout this project. He will be designing the enclosure that will

form the outer shell of the device as well as the 3D layout within the enclosure for optimal compactness and strength. To complete this task effectively, Geoffrey will be required to make 3D models of each component selected by the other group members and arrange them in a way that allows for each device to work together to form a complete PCR machine. The second system he will be responsible is the optical detection system. This system is vital to the operation of quantitative PCR detection and his experience working with medical devices will ensure a functional optical/electronic detection scheme, and ultimately, accurate detection of a virus.

Additionally, Geoffrey will be responsible for the final testing of the completed device. This will consist of preparation of PCR samples that will be used in the device to determine if the final product is able to accurately measure the quantity of target DNA present in the sample. His experience in biosafety labs at the Burnett School of Biomedical Sciences qualifies him to prepare these samples in a safe and accurate fashion due to the training he has received from UCF's department of Environmental Health and Safety (EHS). Since the device will ultimately be tested using a virus, it is Geoffrey's responsibility that any dangers of the virus' escape are mitigated and that testing be conducted in the safest possible fashion in accordance with rules set forth by EHS.

3 Research Related to Project Definition

In order to design the best possible portable PCR device, research must be performed to determine the existing technologies, available components, and benefits as well as problems associated with these technologies and components. This chapter will focus on this phase of the project in detail.

3.1 Existing Similar Projects and Products

Since PCR is one of the most important techniques in the field of biomedical sciences, there are many options available for performing PCR. Examples of these devices are listed in the following section.

3.1.1 Commercial Products

A myriad of commercial products exist to perform PCR, some of those familiar to the authors are presented below.

3.1.1.1 Applied Biosystems 7900HT Fast Real-Time PCR System



Figure 3.1: Example of a conventional qPCR machine at the Burnett School of Biomedical Sciences

Many commercial products, such as the one shown above by Applied Biosystems, are quite expensive and large. For example, the one shown in the figure costs 5 to 10 thousand dollars on the used equipment market, directly from the manufacturer the cost is even greater. This price range greatly reduces the amount of people who are able to access these machines. This being said, there are some additional features present in this type of machine that will not be implemented in our device. More specifically, this device has the ability to use 96 and 384 well PCR plates, allowing for the reaction of many samples simultaneously. Our device will only operate on one PCR tube at a time. This device is shown in figure 3.1.

3.1.1.2 miniPCR

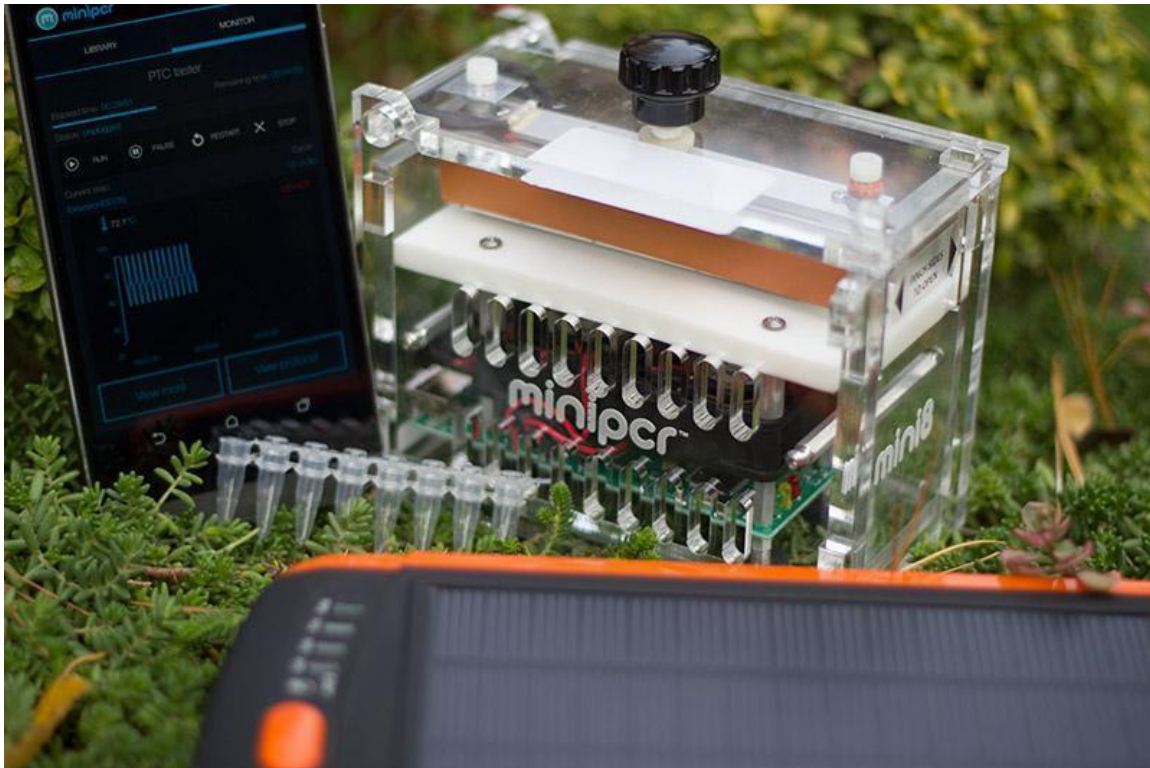

Figure 3.2: The miniPCR device showing its portable nature.

A product that is on the market by miniPCR called the miniPCR device is similar to the device we are proposing. However, the miniPCR has one distinct disadvantage when compared to our device in that it is not designed to perform any detection. The device is simply a thermocycler, meaning all it does is raise and lower the temperature of the sample. Thus, on its own the device is not able to perform any sort of diagnostics. Additionally, the device costs 650 dollars. Our goal for our device is much more cost effective and a more elegant solution for someone desiring an all-in-one device. This is shown in figure 3.2.

3.1.2 Research Projects

Since PCR is such a widespread technique there are already many research projects that desire to produce a compact qPCR machine. Some of them are listed in the following section.

3.1.2.1 Cylindrical PCR

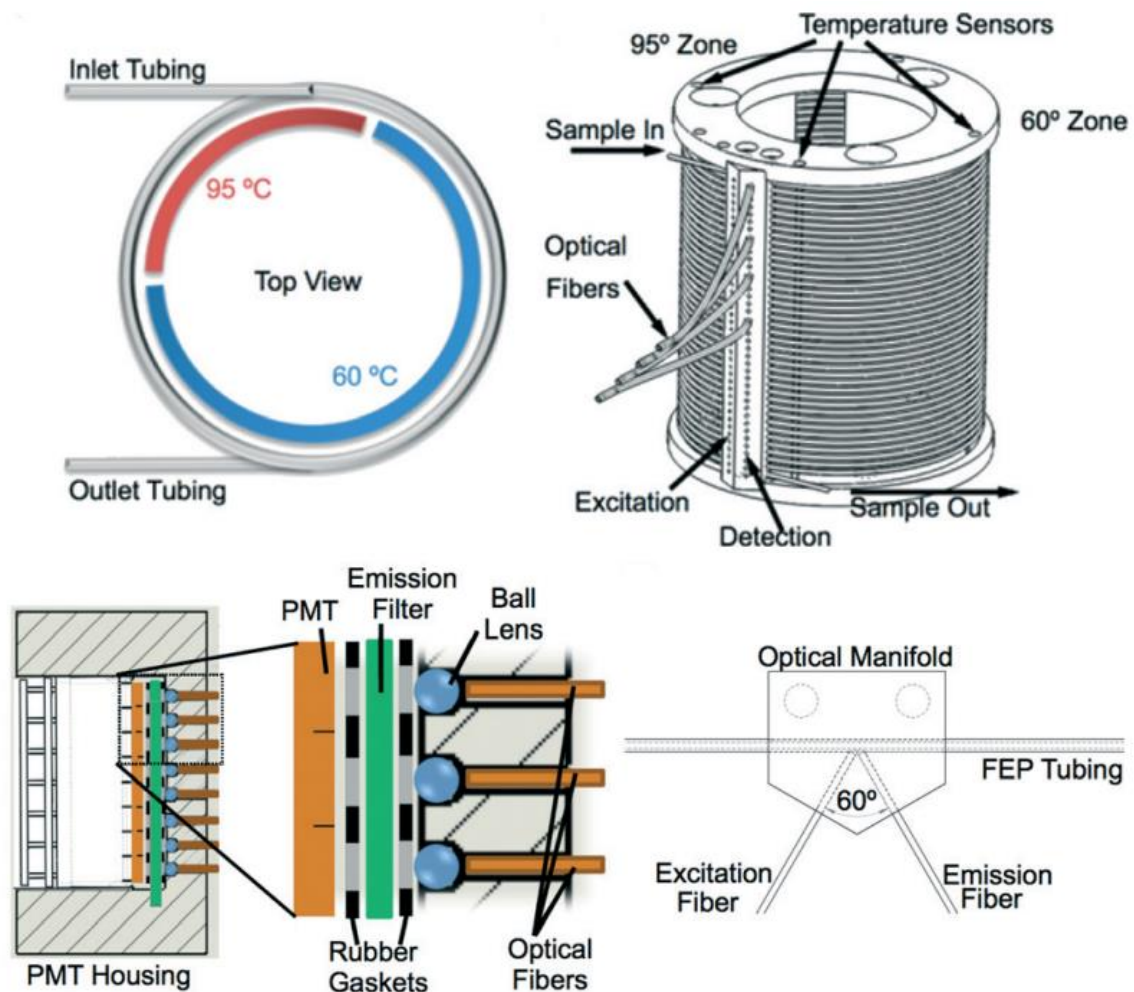

Figure 3.3: A selection of figures from Hatch's paper illustrating the structure of the cylindrical qPCR device.

In this paper by Andrew C. Hatch, et. al. a system consisting of a very interesting heating and cooling technique and detection method is presented. As shown in the figure, the system is based on a cylindrical structure that is wrapped with a tube. The reagents for the PCR reaction are pumped through this tubing and loops around the device around 40 times. One side of the cylinder is kept at 95 degrees and the other side is held at 60 degrees. When the fluid circulates from one side to the other, thermo-cycling takes place. On the cold side, there is an optical

system that excites the sample and takes fluorescence measurements of the sample. This project is interesting as it provides a method which can be miniaturized, however we feel that this is not the ideal solution. However, it demonstrates one of the many ways that a quantitative PCR machine can be constructed. This device is shown in figure 3.3

3.1.2.2 Portable PCR

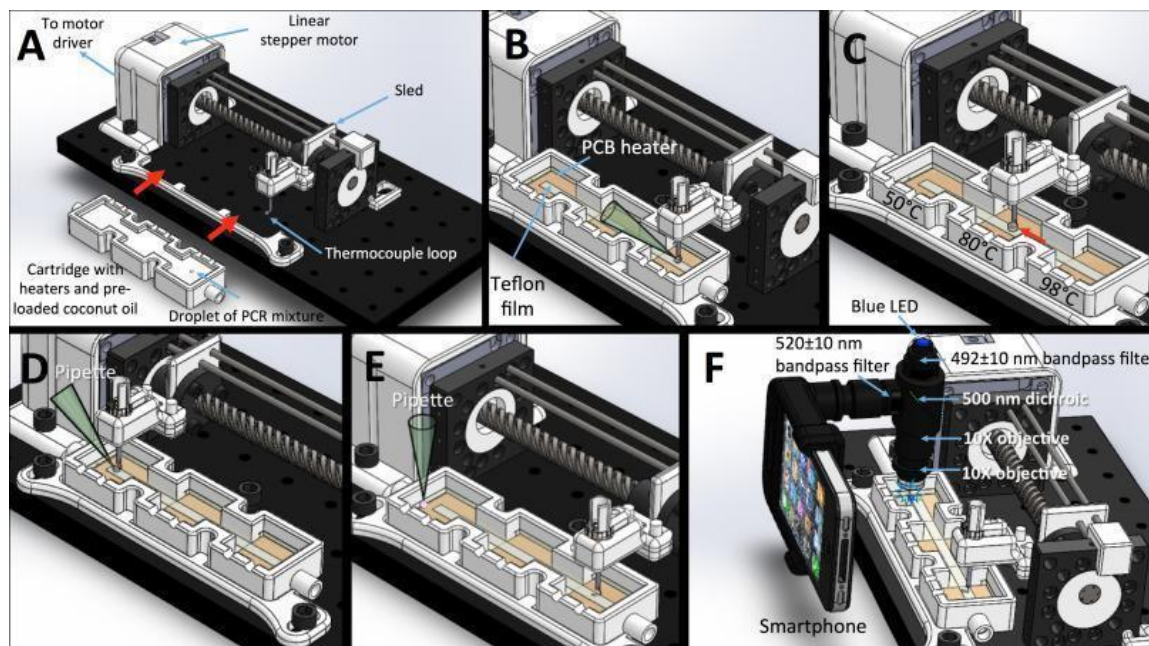

Figure 3.4: This figure shows the inner workings of the device proposed by Mr. Angus.

The device proposed in this paper by Scott V. Angus, et. al. works by moving the PCR sample back and forth between wells being held at different temperatures. The detection takes place using a smartphone, in this case, an Apple iPhone. The iPhone's camera is used through additional lenses to image the sample and perform the fluorescence measurement. The device we are designing for this project will be designed in a similar fashion where the sample will be moved between two temperatures. However, our device will not use the smartphone for the detection, but will instead use the smartphone in a more convenient way for the user. In this way, the device will be operational without being dependent on the use of the cell phone. This device is shown in figure 3.4.

3.2 Relevant Technologies

For this project, there are many existing technologies that will be used in combination to creating a functional PCR device. The details of these

technologies are listed and explained in further detail in the following sections. Each of these technologies were well researched to be able to determine their suitability for our device.

3.2.1 Joule Heating

Joule heating is a process by which heat is released from an electric conductor. The process was first noticed by James Prescott Joule in 1840. Joule is the man for which the SI unit of energy, the Joule, is named. Joule's experiments showed that the heat released by a wire of resistance R carrying a current I during time t is given by the formula:

$$H = I^2 R / t \quad [\text{Joules}]$$

Additionally, the power dissipated as heat in the wire is:

$$P = I^2 R \quad [\text{Watts}]$$

Note that the above formula is equal to the power dissipated by a resistor. As such, Joule heating is 100% efficient. This is because in reality, all resistors function using joule heating as the means by which a voltage drop is created, and power dissipated. As a result, Joule heating will be used in the qPCR device because of its high efficiency. In other words, all of the energy being used in the Joule heating element will be converted into heat, and thus, no energy will be wasted from the batteries of the device.

3.3.7 Thin Film Transistor Liquid Crystal Display

The TFT LCD device works by changing its molecular structure and therefore allow varying levels of light to pass through it (or they can block the light). Two polarizer filters, color filters and two alignment layers determine exactly how much light is allowed to pass and which colors are created. The layers are positioned between the two glass panels. A specific voltage is applied to the alignment layer, creating an electric field - which then aligns the liquid crystals. Each dot on the screen (pixel) therefore requires three components, one for red, green and blue (Figure 3.5).

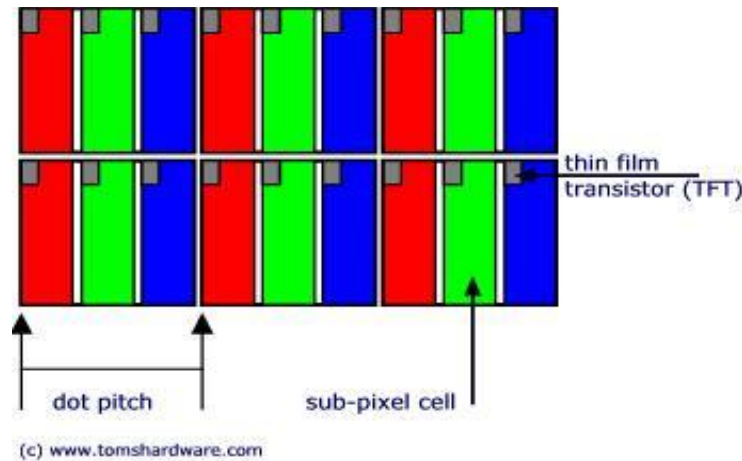

Figure 3.5: Pixels of a TFT.

The color filters for red, green and blue are integrated on to the glass substrate next to each other. Each pixel (dot) is comprised of three of these color cells or sub-pixel elements. This means that with a resolution of 1280 x 1024 pixels, exactly 3840 x 1024 transistors and pixel elements exist. The dot or pixel pitch for a 15.1 inch TFT (1024 x 768 pixels) is about 0.0188 inch (or 0.30 mm) and for an 18.1 inch TFT (1280 x 1024 pixels) it's about 0.011 inch (or 0.28 mm).

3.2.2 Thermistor

A thermistor is a type of resistor whose resistance is dependent on temperature, more so than in standard resistors. The word is a combination of the words thermal and resistor. Thermistors are widely used as inrush current limiter, temperature sensors (Negative Temperature Coefficient or NTC type typically), self-resetting overcurrent protectors, and self-regulating heating elements (Positive Temperature Coefficient or PTC type typically). Thermistors are of two opposite fundamental types. With NTC, resistance decreases as temperature rises to protect against inrush overvoltage conditions. Commonly installed in parallel as a current sink. With PTC, resistance increases as temperature rises to protect against overcurrent conditions. Commonly installed in series as a resettable fuse. We will be using the a NTC thermistor as our temperature sensor because it requires only one other external component to achieve accurate temperature readings. We will be using the thermistor in a voltage divider configuration shown in Figure 3.6 which will vary the output voltage of the divider depending on the temperature of the thermistor.

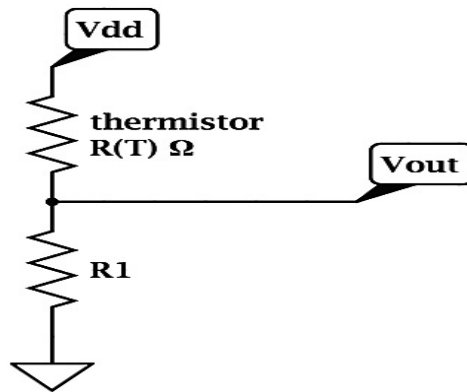

Figure 3.6: schematic diagram demonstrating a temperature sensor using a thermistor.

The thermistor we will be using is an NTC 10k ohm SM103J1K-TR manufactured by US sensor. This thermistor comes in a MELF package as shown in figure 3.7.



Figure 3.7: image of MELF package.

This is an advantage to us because this package can be directly soldered to our joule heater and conduct heat with relative ease due to its exposed nature, giving us a more accurate temperature reading. We chose this over the other thermistors because of its low thermal coefficient, as well as its thermal stability.

3.2.3 Inter-integrated Circuit Protocol (I2C)

This PCR machine will also be using I2c internally to communicate between the MCU and the BQ24297 charging IC. The Inter-integrated Circuit (I2C) Protocol is a protocol intended to allow multiple “slave” digital integrated circuits (“chips”) to communicate with one or more “master” chips. Like the Serial Peripheral Interface (SPI), it is only intended for short distance communications within a single device. Like Asynchronous Serial Interfaces (such as RS-232 or UARTs), it only requires two signal wires to exchange information.

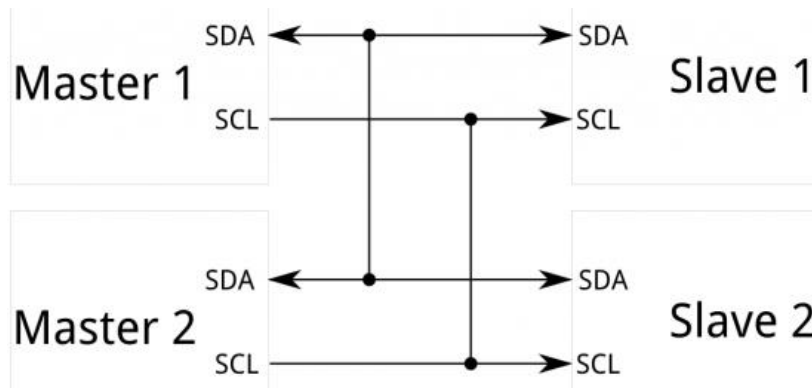

Figure 3.8: I2C Connection example

I2C requires a mere two wires, like asynchronous serial, but those two wires can support up to 1008 slave devices. Also, unlike SPI, I2C can support a multi-master system, allowing more than one master to communicate with all devices on the bus (although the master devices can't talk to each other over the bus and must take turns using the bus lines). Data rates fall between asynchronous serial and SPI; most I2C devices can communicate at 100kHz or 400kHz. There is some overhead with I2C; for every 8 bits of data to be sent, one extra bit of meta data (the "ACK/NACK" bit.)

Each I2C bus consists of two signals: SCL and SDA. SCL is the clock signal, and SDA is the data signal. The clock signal is always generated by the current bus master; some slave devices may force the clock low at times to delay the master sending more data (or to require more time to prepare data before the master attempts to clock it out). This is called "clock stretching" and is described on the protocol [page](#).

Unlike UART or SPI connections, the I2C bus drivers are "open drain", meaning that they can pull the corresponding signal line low, but cannot drive it high. Thus, there can be no bus contention where one device is trying to drive the line high while another tries to pull it low, eliminating the potential for damage to the drivers or excessive power dissipation in the system. Each signal line has a pull-up resistor on it, to restore the signal to high when no device is asserting it low.

Communication via I2C is more complex than with a UART or SPI solution. The signalling must adhere to a certain protocol for the devices on the bus to

recognize it as valid I2C communications. Fortunately, most devices take care of the details.

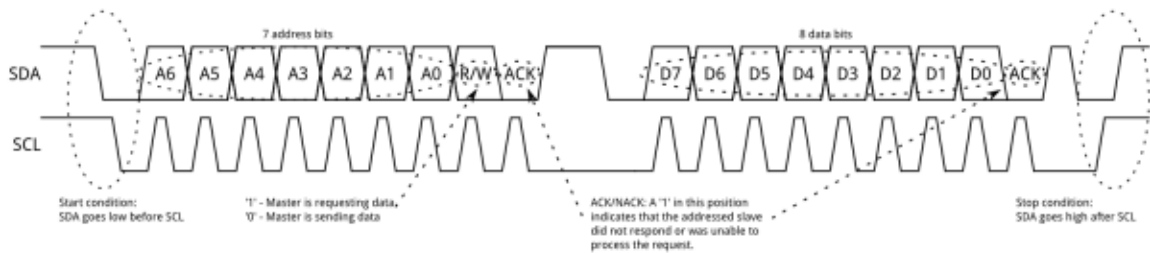

Figure 3.9: Clock cycle

Messages are broken up into two types of frame: an address frame, where the master indicates the slave to which the message is being sent, and one or more data frames, which are 8-bit data messages passed from master to slave or vice versa. Data is placed on the SDA line after SCL goes low, and is sampled after the SCL line goes high. The time between clock edge and data read/write is defined by the devices on the bus and will vary from chip to chip.

3.2.4 Serial Peripheral Interface (SPI)

This PCR machine will be using SPI internally to communicate between the MCU and the TFT LCD display. Serial Peripheral Interface (SPI) is an interface bus commonly used to send data between microcontrollers and small peripherals such as shift registers, sensors, and SD cards. It uses separate clock and data lines, along with a select line to choose the device you wish to talk to (figure 3.10).

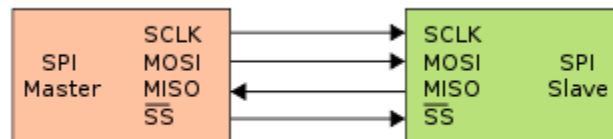

Figure 3.10: SPI Connections

To begin communication, the bus master configures the clock, using a frequency supported by the slave device, typically up to a few MHz. The master then selects the slave device with a logic level 0 on the select line. If a waiting period is required, such as for analog-to-digital conversion, the master must wait for at least that period of time before issuing clock cycles. During each SPI clock cycle, a full duplex data transmission occurs. The master sends a bit on the MOSI line

and the slave reads it, while the slave sends a bit on the MISO line and the master reads it. This sequence is maintained even when only one-directional data transfer is intended, shown in figure 3.11.

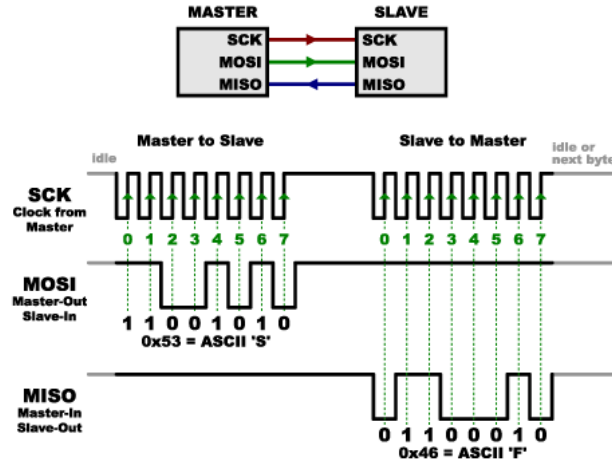

Figure 3.11: Clock cycle

Transmissions normally involve two shift registers of some given word size, such as eight bits, one in the master and one in the slave; they are connected in a virtual ring topology. Data is usually shifted out with the most-significant bit first, while shifting a new least-significant bit into the same register. At the same time, Data from the counterpart is shifted into the least-significant bit register. After the register bits have been shifted out and in, the master and slave have exchanged register values. If more data needs to be exchanged, the shift registers are reloaded and the process repeats. Transmission may continue for any number of clock cycles. When complete, the master stops toggling the clock signal, and typically deselects the slave. Every slave on the bus that has not been activated using its chip select line must disregard the input clock and MOSI signals, and must not drive MISO.

3.2.5 PID

The thermistor will provide valuable real time information on what the temperature of the thermal blocks is but what the microcontroller's program will do with that information is very important. The microcontroller will use the information to keep the blocks at the desired temperatures which may seem pretty simple but is actually probably the one of the complicated process of our program. There are many ways to make sure they reach and stay at the desired temperatures but we want to find the best one since heating our sample to a very specific temperature

is rather important. To achieve the best possible solution, we need to define some parameters such as a set point, level of tolerance, and proportional band. The set point is the desired temperature we wish to achieve in the quickest and most stable way. The level of tolerance is how much error there is room for, mostly in case we have some oscillation in overshooting and undershooting our set point. The proportional band is a certain distance above or below the set point where we will start to slow down heating or cooling to really fine tune onto our set point.

There are a few techniques of the kind of control we are looking for. The first one considered for its extreme simplicity is simple On/Off control. This idea is that the temperature is increased until it reaches the desired set point for the temperature and then simply turned off until the thermistor senses that the temperature has dropped below the set point. Once that occurs the heating blocks are told to heat again until it reaches the set point again. This technique is quite simple and creates a lot of oscillation around the set point decreasing efficiency and can easily exceed our level of tolerance and is very susceptible to outside noise.

The other widely used technique for the control we need is PID control. PID control uses a system like that shown in Figure 3.12. Our set point (SP) for the temperature is compared to the Process Variable (PV), given to the microcontroller from the sensor (thermistor). The microcontroller compares the actual value to the set point value and sends a signal to react accordingly creating the process to adjust the temperature.

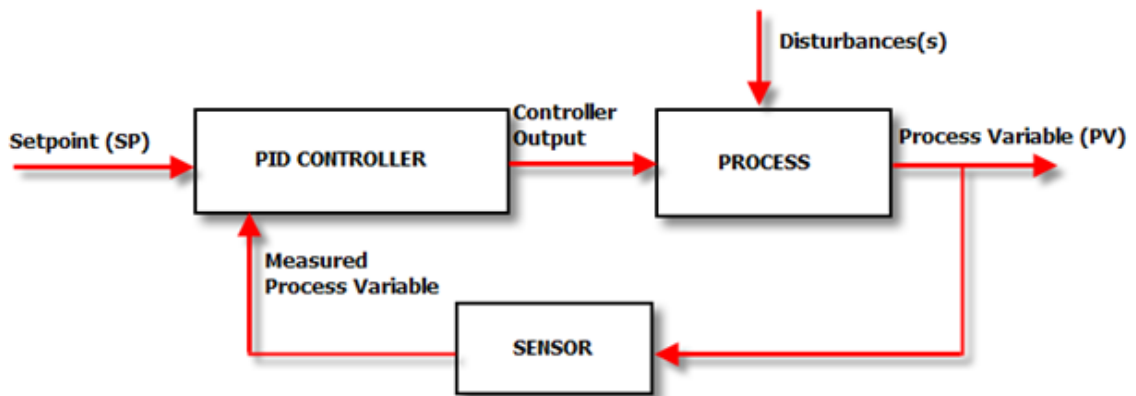

Figure 3.12: This diagram shows the block diagram for a typical PID controller system.

The program the microcontroller runs will subtract the set point from the process variable and multiply it against 3 separate variables P,I, and D before adding them back together to create the output for reaction as seen in figure 3.13. P stands for

the proportional gain control constant tuned to get our desired performance. I is the Integral action, tuned by adjusting a term called “minutes per repeat” a measure of how long it will take to the integral action to add up to equal the proportional action. D is the derivative action. The derivative action looks at the current rate of change and tries to adjust itself based on future predictions of how long it will take to achieve or maintain the set point. Having the D term allows for higher P and I terms while keeping the system as stable as possible, allowing for a quicker response.

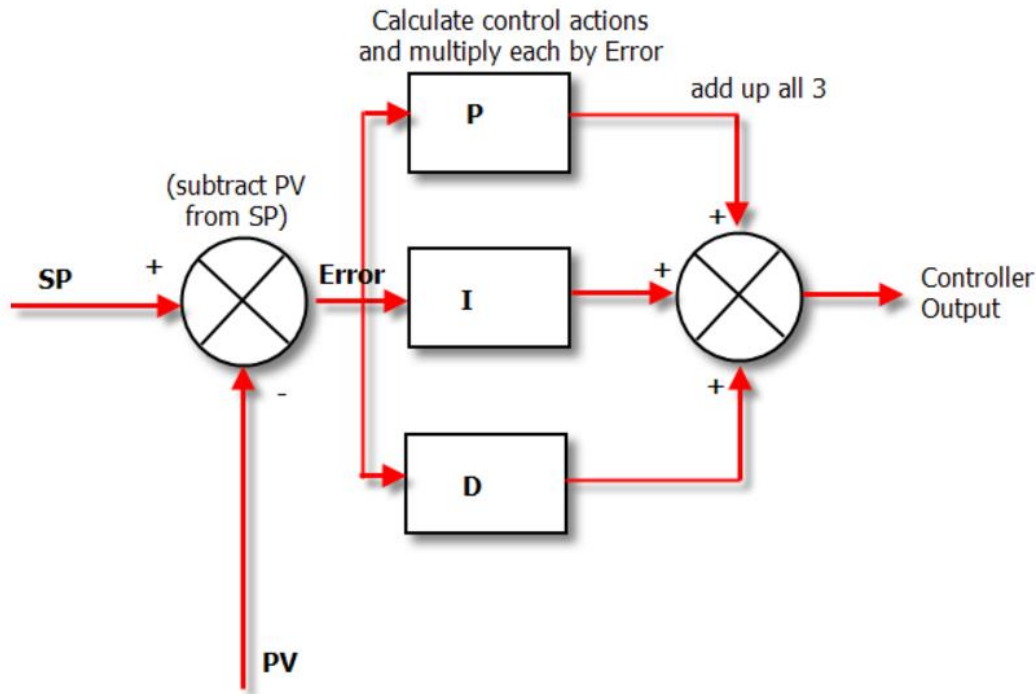

Figure 3.13: Block diagram of a PID controller system.

This process will be run in a loop intuitively named a loop response. The loop response can create one of three situations in response to input: under, critically, and over damped (seen in figure 3.14). Underdamped is a situation in where the set point is reached with almost no overshoot but the system arrives there relatively slowly. Critically damped is the ideal situation where the set point is reached with little to no overshoot as quickly and efficiently as possible. Underdamped in the situation best avoided where the process is too fast, overshoot occurs and may result in inefficient oscillations. Our ideal process would begin quickly and about the time it reached the proportional band begin to come to a slow leveling off before overshooting and stabilizing at the set point.

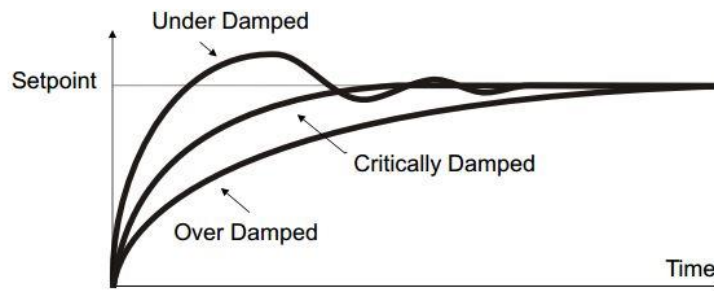

Figure 3.14: The various specifications of damping.

To tune the PID control, we must first turn off the Integral and Derivative terms and set the Proportional band to a minimum which will create an oscillating signal much like the on/off technique. With that signal, measure the width of the oscillation (X_{osc}) and period of each oscillation (t_{osc}) to use in the calculations for each constant (seen in figure 3.15). The final constants should be as follows: $P = 2.0 \cdot X_{osc}$; $I = 1.5 \cdot t_{osc}$; $D = I / 5$. These will actually result in a slightly overdamped result and can be slightly reduced for a quicker response.

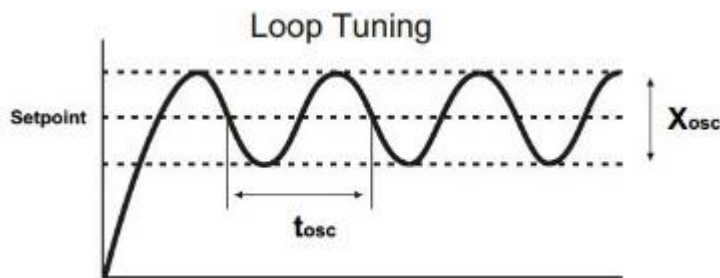

Figure 3.15: Oscillations used for loop tuning.

3.2.6 Universal Asynchronous Receiver/Transmitter (UART)

The Universal Asynchronous Receiver/Transmitter (UART) is a standard used in many electronics to connect components such as Bluetooth and GPS modules to a microcontroller, both of which are being accounted for in the PCR machine. UART connections insure efficient and widely supported communications between the microcontroller and another computing module. It is not its own protocol but a physical circuit in the microcontroller whose main purpose is to transmit and receive serial communications.

UARTs are so commonly used for their simplicity, needing only two wires to communicate parallel data. One UART transmitter turns CPU data into serial data

to be sent through one wire to the other UART connection that transforms the serial data back into parallel data. As shown in figure 3.16, Tx can send a message through a single wire to Rx while the other does as well. Information is simply taken from the data Bus, given a start bit, a parity bit, and stop bit, and sent to the other UART to be transformed back into the parallel information, removing the start, stop, and parity bits.

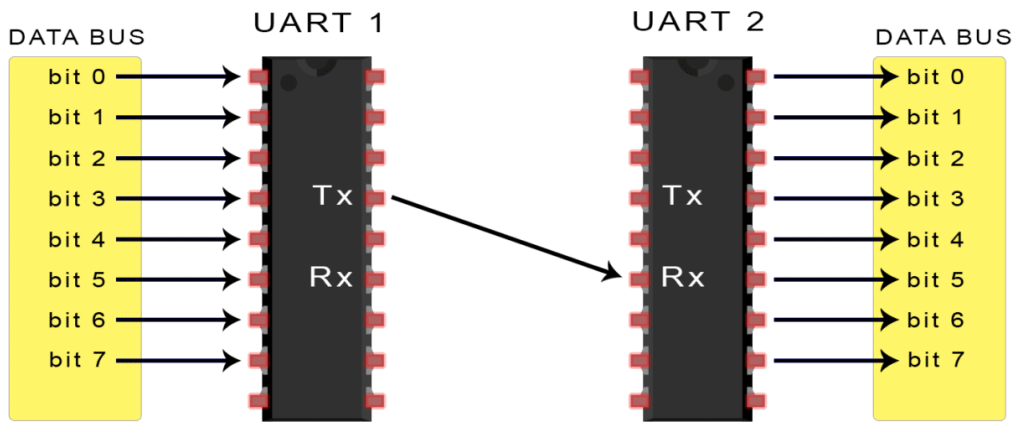

Figure 3.16: Basic structure of communication between two UARTs.

UARTs run asynchronously meaning they have no clock to govern when they can send and receive information. To account for this simple start and stop bits that are encoded into the packets tell the other connected UART when to start and stop reading a message. The only constraint to this is that both UARTs must have a similar baud rate, or rate at which data can be read which must be at least within 10% of each other.

UART information is sent in simple packets consisting of a start bit, around 5-9 data bits, an optional parity bit, and 1 to 2 stop bits as shown in figure 3.17. The start bit is usually represented as a zero. This is because when not transmitting any data, the transmission line is usually held at a high voltage and once it reads a low cycle it begins to start reading. The data section contains the data to be read starting with the least significant bit first. Depending on the devices used it can have from 5-8 bits and even a 9th if the parity bit is not used to send the data that was once parallel in a serial form. The parity bit is mostly there to check for potential errors. Since the UART is usually a rather short wired connection it is rare and not very likely to happen, but radiation and longer distances can corrupt the data nonetheless. It simply checks to see if the number of 1's in the message was even or odd. A parity bit of 0 mean even parity, there should be an even number of 1's in the data, if not then the UART knows an error has occurred. The stop bit is usually just the UART driving the lower voltage back to a higher voltage for at least 2 read durations to signal a stop.

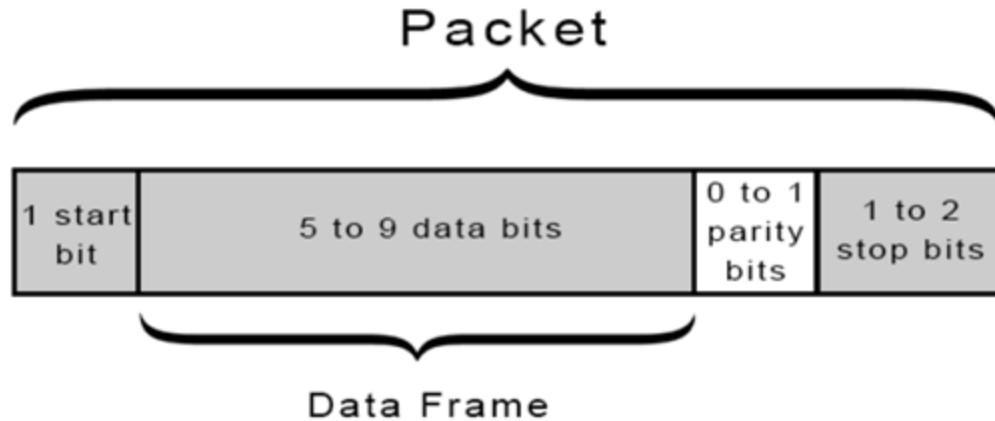

Figure 3.17: Breakdown of a packet sent by a UART, showing the bit fields and data frame location.

One downside of UART connections is that it does not support multiple master or slave systems and has a rather limited size of the data that can be sent. The ATmega2560 microcontroller accounts for this downside with its 4 UART connections allowing us to control a few slave systems at once. We have decided to stay with it for its simplicity of use, lack of need for a clock signal to be synchronized with it, and because it is so well documented and widely supported among most small electrical systems. It will be extremely useful in talking with our Bluetooth module, display screen, and GPS module.

3.2.7 Position Tracking

We have many standards for our device and plan on achieving all, if not more than, our goals. A goal that we consider important for a device like ours, a portable PCR machine, is to be able to collect as much data as we can and be able to record that data very quickly. Much of the data that our device is planning on collecting in the future is disease based, and from all over the world. If diseases once detected or not detected, can be then given a location with the test results, the results would help determine outbreaks and what areas and regions of the world the public may stay clear of and help contain those areas with a high concentration of people affected. We find that a position tracking mechanism on the device will aid to the research significantly. Having the position tracking mechanism on the device directly allows for the device to have this feature and be able to operate independently of its co-operating device, the smartphone and app. We will examine the direct types of location tracking devices and determine the best fit for our use.

3.2.7.1 Global Positioning System (GPS)

GPS stands for Global Positioning System. It is the most publicly used of all the position tracking devices. Initially it was designed for United States military purposes but altered and became available for public use however is very much controlled and operated by the United States Department of Defense. GPS was first launched in 1978. Since then there have been 71 launches following the first launch. There are a total of 32 satellites, each of which is orbiting around 20,180 km. It was designed to be better and triumph over the preexisting navigation technologies, although a part of its design is stemmed from previous technologies. The GPS is based on the time and position of the current satellites. Each satellites operates using an atomic clock, that are all in sync with all other satellites and clocks that are on Earth. For precision purposes the clocks are updated continuously and the locations of all the satellites are closely monitored with extreme precision. The process involves satellites, ground stations, and receivers. The satellites orbit in a very particular manner so that at any moment every location on Earth can be determined. The orbit is referred to as orbital planes, and there are six of these planes. Satellites are constantly sending signals of their information, such as time and location. The time of arrival (TOA) is measured from the receiver. Along with the time of transmission (TOT). With these measurements the receivers are able to obtain a specific radius of a distance from each satellites that is in range of the receiver. The receiver is then able to detect the intersection of all the circumferences of the distances from the data obtained through a process called trilateration. GPS currently is as precise as 5 meters and expected to increase its precision in the future.

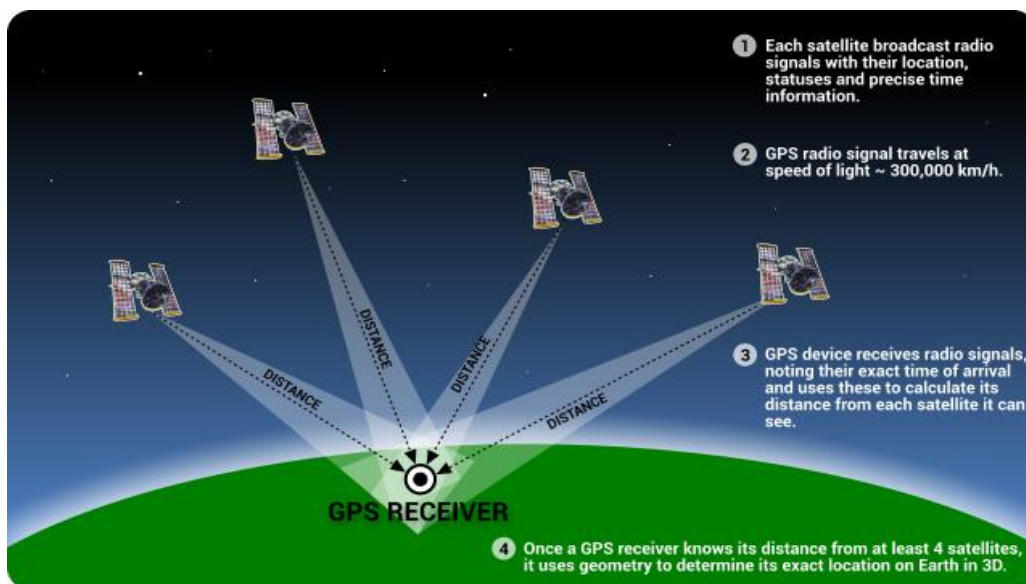

Figure 3.18: This figure demonstrates how receivers are able to determine their location using GPS

3.2.7.2 GLONASS

GLONASS is Russian technology that stands for Globalnaya Navigazionnaya Sputnikovaya Sistema which is translated as Global Navigation Satellite System. GLONASS is thought to be the Russian GPS and is GPS's closest competitor. GLONASS has a similar number of satellites at 27 but operates at an altitude of 19,130 km, closer than that of GPS. Like GPS is it both military and civilian operated. GLONASS is also very accurate. GLONASS has a precision from 4.5 to 7 meters. GLONASS' first launch was in 1982. GLONASS is very functional for position tracking technology and operates independently from GPS. However, most smartphones today have the ability to use GPS as well as GLONASS to track their positions. This gives the benefit to the users, as they are able to get the best accuracy from the best suited positioning system given different locations. GLONASS is best suited for the northern and southern hemispheres of the Earth because it was initially designed for Russia. Their orbital plane inclination is different than that of GPS by about 15 degrees for the very reason that the system is more precise at that angle in Russian territory. The market commercially for GLONASS is not very large and devices that are exclusively GLONASS aren't very common outside of the military and civilians of Russia. A-GLONASS is typically what is found in smartphones, just as A-GPS is also found in smartphones. The A stands for assisted, this allows for the turn by turn navigation and current traffic information. Other considerations for position tracking are available such as Galileo and BeiDou Navigation Satellite System however these are far inferior to the GPS and GLONASS and thus will not go into further detail.



Figure 3.19: This figure shows the GLONASS Orbital Planes. These are meticulously assigned to assure that receivers in all areas of the world can track their positions. The orbit of GLONASS different than that of GPS.

3.2.7.3 Android Location Services

Working with the app we are also able to use the built in location services from the mobile device to determine location. Android's location services can use GPS navigation but also use a few other techniques to help quickly estimate position at first while waiting for GPS radio waves to get bounce back, which is a lengthy and battery consuming process.

The first technique to help determine a mobile device's location is by correlating it with the nearby cell towers. When connected to a tower, service providers can estimate how far you are from the known fixed tower location based on how strong the signal is. A radius of possible locations based on the signal strength is then created. Other towers nearby can then use a similar technique to really narrow down your position quickly to two possible places, at the intersections where the two radii cross each other. With a third tower, your exact position can be estimated within a few hundred feet because all three should intersect at a single point as seen in figure 3.20.

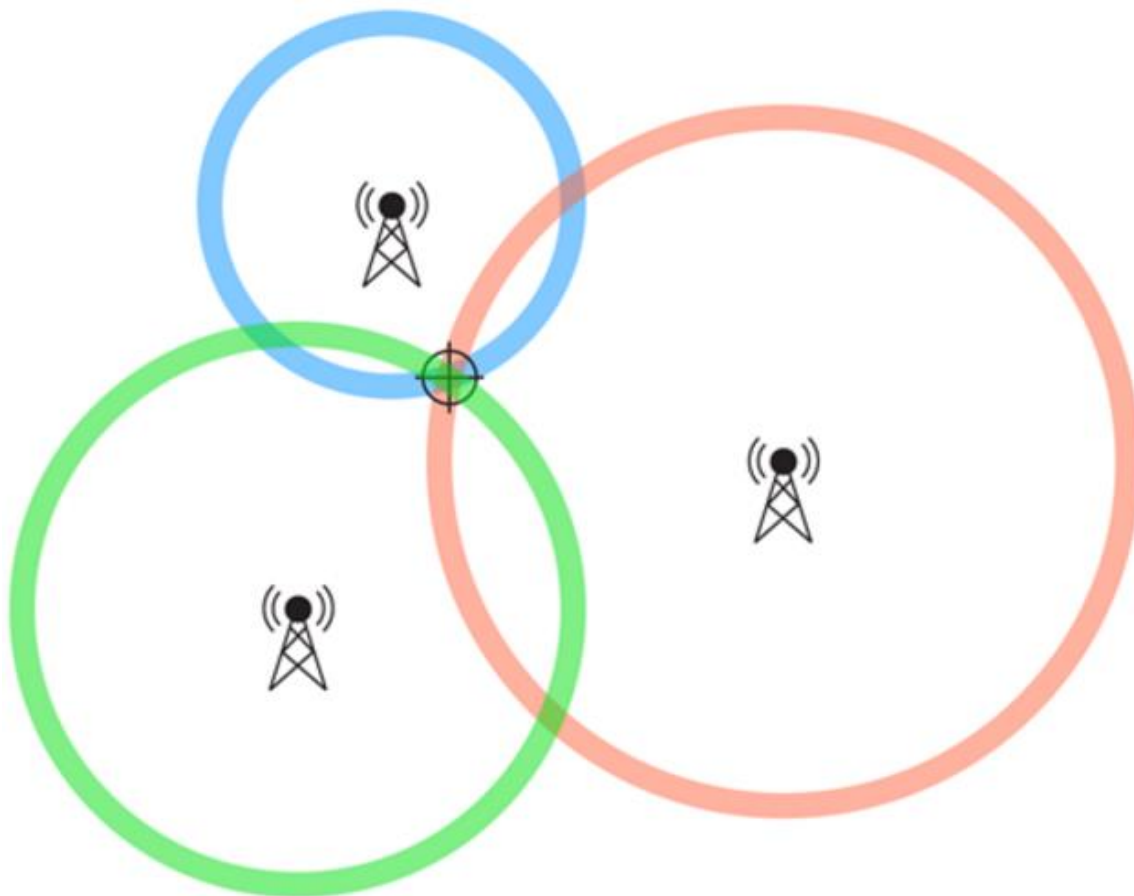

Figure 3.20: A visualization of how three cell towers can help triangulate your position from your mobile phone

Another technique used commonly that is even more accurate is a similar technique based on wifi connections. It is the most efficient battery and location wise using the least power and being able to coordinate your position within a couple of feet. Its drawbacks are a need for wifi connections which are only common in developed urban areas as well as a need for a known database of these wifi sources.

Although the Android's location services are very useful and could alleviate some strain on our system we do not want to create a product that relies on a cellular device. We will still include a positioning unit in our stand alone device and probably just allow those using the android device to use their location services to record their position on the online database.

3.2.7.4 Decision

As mentioned previously all tracking basically operates in the same manner. Our choice of selection is GPS. There are numerous satellites revolving around Earth and every receiver on Earth that requests for its location has the satellites send a signal to the device and receives the signal back, which makes the GPS satellite able to determine a radius of the distance from which the device is located. Numerous satellites do this same process, also having their own radius of distance. Trilateration is then the process required to pinpoint a highly accurate location by taking the radius of distances and retrieving the point of their intersections. Commonly three satellites are used.

GPS seemed like the most logical choice of use because it allows our device to collect location data autonomously. GPS is very commercially based and widely used which makes locating the parts needed to install and getting them at a low cost far better than alternatives. For marketing purposes, GPS in itself is a name recognized. To be able to put GPS capabilities alongside its description of the portable PCR machine will give our device an extra additive.

There are some considerations for the GPS being incorporated with the device. Here is a list of pros and cons for further thought.

Pros

- Autonomous location data
- Better selling point in the market

Cons

- Can still achieve same data but dependent on the smartphone's GPS
- Makes the device more expensive
- Adds small amount of weight and space

3.2.8 Pulse Width Modulation (PWM)

Pulse width modulation (PWM) is a method for encoding information using an extremely simple binary signal. The encoding scheme works by modifying the period of time that the signal is held at the positive value. The frequency of the waveform is held at a constant value. Usually, the value being transmitted is at its highest value when the positive period is at its largest possible value and at its lowest when the positive period is at its shortest possible value. In this project, this modulation scheme is used to control the positions of the servo motors used to position the PCR sample tube. To control the position of the servo motors, various positive widths will be sent to the servo motor via the microcontroller. This operation is shown in Table 3.1 and figure 3.21.

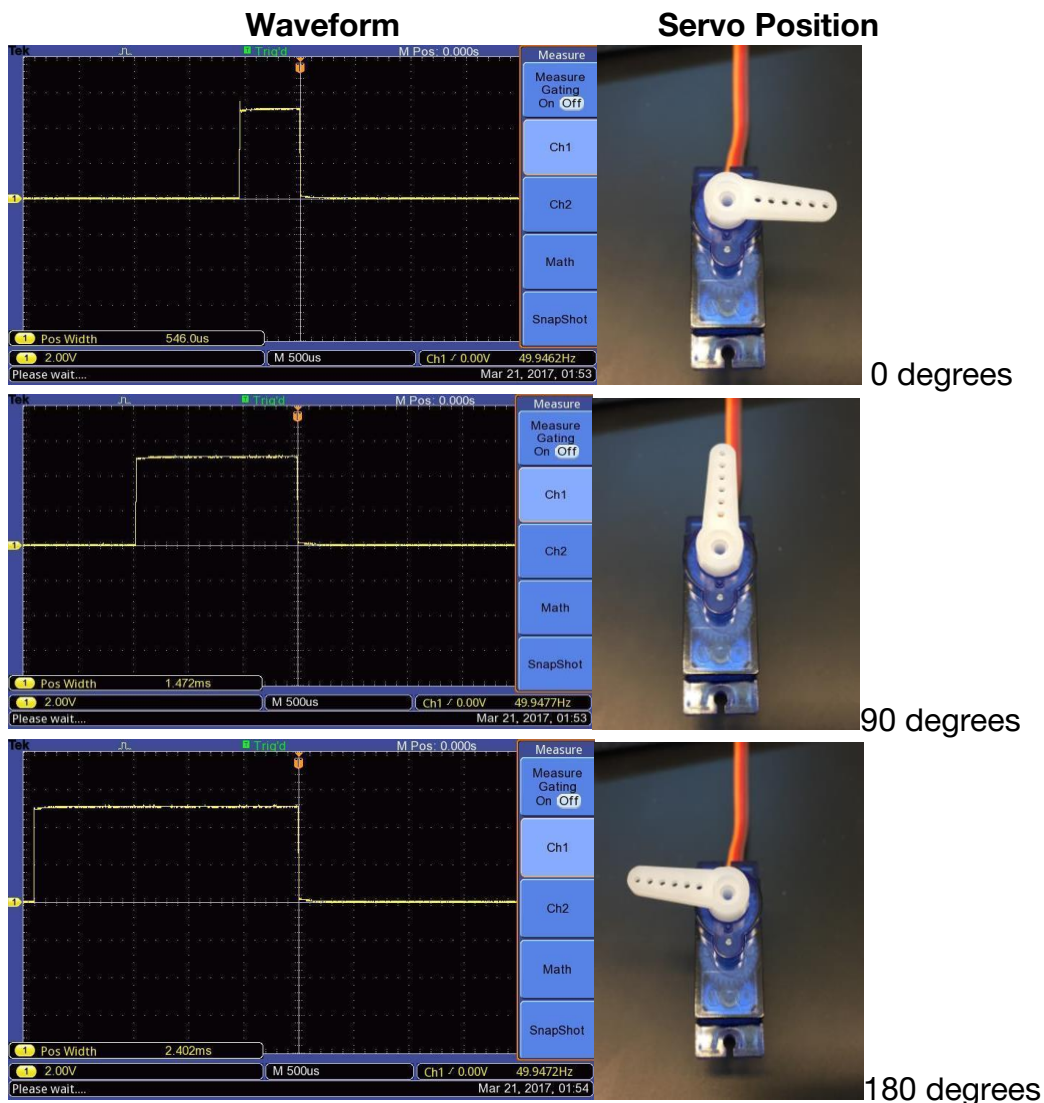

Figure 3.21: The servo positions resulting from various PWM.

Positive Width (ms)	Angular Servo Position (degrees)
0.546	0
1.472	90
2.402	180

Table 3.1: The servo positions resulting from various positive periods by PWM.

Using the data from the table, it becomes clear that the equation governing the positioning of the servo θ with respect to the positive width W is:

$$\theta = 90 (W - 0.546) \quad [\text{Degrees}]$$

This formula will be used to control the servo motor to allow for positioning at arbitrary angles. The servo motors will be used in this project to position the heating and cooling elements in the correct locations accurately and precisely within the machine.

3.2.9 Optical Components

Various optical components are required to create a functional system for the detection of fluorescence from within the sample. The main components of the system are the Photodiode, the LED, and the optical filters.

3.2.9.1 Photodiodes

One of the most important parts of a qPCR system, and the element that distinguishes it from a simple thermocycler is the optical detection system. One common way this system works is by use of a photodiode. A photodiode is a simple solid-state component which takes in light and produces electrical current. The structure of the device is usually an N-type device, meaning that an N-type substrate is doped with a P-type region. Between the doped region and the substrate, a layer is formed called the depletion region where the net charge is zero. The P-type region is where the light will strike the photodiode as it is located on the surface. Due to the photoelectric effect, when photons hit this region with an energy larger than silicon's bandgap, an electron-hole pair is produced. These electron-hole pairs drift apart and in the case of an N-type photodiode, the holes cross over the depletion zone. Thus, current flows between the connections to the device. This current can be measured using a transimpedance amplifier and will output a voltage proportional to the light incident on the photodiode.

3.2.9.2 Light Emitting Diodes (LED)

Yet another component in a qPCR system is some form of light source. This light source is the means by which the fluorescent probes are excited to the point where they emit their own light. To perform this task, a light source usually consists of an LED. A LED is a solid-state device that electrically functions as a standard diode, however, the device is optimized to emit light. It does so when the charge carriers fall from the conduction band to the valence band and recombine. By tuning the gap between the conduction and valence band, the wavelength of the photons produced can be controlled. The equation for energy contained in a photon of light is

$$E = hc / \lambda$$

Where h is Planck's constant or, $4.14 \times 10^{-15} \text{ eV} \cdot \text{s}$, and c is the speed of light or $2.99 \times 10^8 \text{ m/s}$. If we want to know the bandgap required to produce blue light of wavelength 470 nm, the wavelength of the LED that will be used to excite the sample in this project, we can use the formula and find $E = 2.633 \text{ eV}$.

3.2.9.3 Optical Filters

A critical component of a functional optical system is the choice of filters. These filters perform the task of rejecting wavelengths of light that are not desired. This allows for the excitation for the sample only at the correct wavelength and for the reading of only the correct wavelength of emission. For this project we will select filters from Omega Optical. This source is ideal because of their wide variety of sizes that are available and their offerings of specific wavelengths.

3.2.10 Wireless Communications

Wireless Communications allow external devices to communicate with each other and while doing so without any wires. Wires get pulled and tripped upon and connecting to another device would require an additional cable available for use; so to avoid these hazards and inconveniences, we will use wireless communication. Our goal for the portable PCR machine is to be autonomous but also be able to connect to an app on a smartphone and have the app control the device. The app for the device will be have many more features and allows for data to be sent to database if the user would like.

Wireless communication has legal constraints and must be considered independently. The FCC has regulated telecommunications and must be considered for the sake of avoiding charges from the federal government. For wireless communication to be possible, it involves frequencies to be transmitted.

However many of the frequencies that are operable and practical for communications are licensed. The United States frequency allocations are commonly known and they display the frequency allocations in the United States. We know from this that many large blocks and also lots of very tiny blocks are also present. Unfortunately for many civilians the majority of both large blocks and small blocks are licensed and are restricted for public use. Only a few of the small blocks in frequencies are free for public use, there are also some large blocks that are free for anyone to use however they are all frequencies that cannot be used for any communication application. For this reason it is of great importance that we are sure that the wireless communication we are conducting does coincides with the regulations set forth by the FCC.

When looking at the frequency allocations of the United States it is difficult to see every frequency domain and many of the assigned frequencies to the different fields. However, what can be seen is that everywhere on the frequency spectrum the FCC has closely assigned nearly all of the frequencies available. Very few of what's shown is open to public use.

Since most of the open frequencies are extremely limited, it will be very difficult to find our own way of communicating wirelessly. Therefore we will focus on the current technologies that are both not interfering with the regulations of FCC and practical means of wireless communication.

3.2.10.1 Bluetooth

Bluetooth is the new age of wireless communication among devices. It was created in 1994 and was named after a Danish king. Bluetooth was designed for short distance communication for exchanging data wirelessly in an open area network. Bluetooth operates in the short range radio frequency band, which allows large quantities of data to be sent in a given frequency. The process is known as frequency hopping, which helps avoid interference and lagging. Bluetooth operates in an open network therefore uses the unlicensed ISM band, which stands for Industrial, Scientific, Medical devices band, Wi-Fi also operates in this band. The bandwidth is based upon 2.4 GHz. However, the range of frequencies is open so Bluetooth uses frequency hopping by jumping or finding an available frequency that is open to operate with.

Bluetooth operates in the Master - Slave uniform. A master is able to control the slave and the slave simply acknowledges. A piconet is a network formed when a master is connected to one or more slaves and are synchronized to a clock and all slaves are operating with the same frequency hopping pattern. A slave and master can switch roles as the slave becomes the master and the master becomes the slave if called for by the devices. These two can communicate with

each other but two slaves even if on the same piconet cannot communicate with each other.

Bluetooth has three different classes that it operates in. Class 1 operates with 100 mW and can function up to a distance of approximately 100 meters. These are typically used for industrial purposes. Class 2 operates with 2.5 mW and can function up to a distance of approximately 10 meters. Class two is the most used of the classes and are typically found in most common devices today. Class 3 operates with 1 mW and can function up to a distance of approximately 1 meter. Class 3 is the least used out of all the classes. Bluetooth is not designed to handle two masters, although they can be paired only one can control at a given time. Along with classes Bluetooth also has different versions. The ones I will compare are Bluetooth 1.0, Bluetooth 2.0, Bluetooth 3.0, and Bluetooth 4.0

- Bluetooth 1.0
 - The debugging stage of Bluetooth technology.
 - Up to 1 Mbit/sec
- Bluetooth 2.0
 - Enhanced data rate (EDR) was introduced allowing for a faster rate of 3 Mbits/sec
 - Allowed for easier pairing among devices
- Bluetooth 3.0
 - Introduced a new feature called high speed (HS) that allowed data to be transferred to other HS compatible devices over a 802.11 link.
 - Up to 24 Mbits/sec
- Bluetooth 4.0
 - Also known as Bluetooth Smart
 - Ultra-power saving mode, however only compatible with 5.0 devices

PART	Specification
Bluetooth Spec.	Bluetooth Specification 2.0 Support
Communication distance	10M
Frequency Range	2.4GHz ISM Band
Sensitivity	-83 dBm(Typical)
Input Power	3.3V
Current Consumption	48mA(Max)
Communication Speed	1,200bps ~ 230,400bps
Antenna	Chip Antenna
Interface	UART(TTL Level)

Table 3.2: This displays the basic specifications of a Bluetooth module. These specifications will be considered when making our wireless communication technology decision.

3.2.10.2 Infrared

Infrared also known as IR is a wireless communication technology. Infrared is a very cheap form of wireless communication and is commonly used for communication purposes. Most homes contain a device that operates using infrared technology. The most famous example is the television remote controller. Infrared communication operates using Infrared light. Infrared light falls on the wavelength spectrum ranging from 700 nanometers (nm) to 1 mm. Infrared light is not visible light, although it borders visible light on the electromagnetic spectrum. Infrared has larger wavelengths than that of light. Since humans can not physically see infrared light it makes it a great form for wireless communication. Common sources of infrared typically emit both infrared and visible light and in some cases many other wavelengths along the spectrum. The sun is a great example of that, as well as light bulbs.

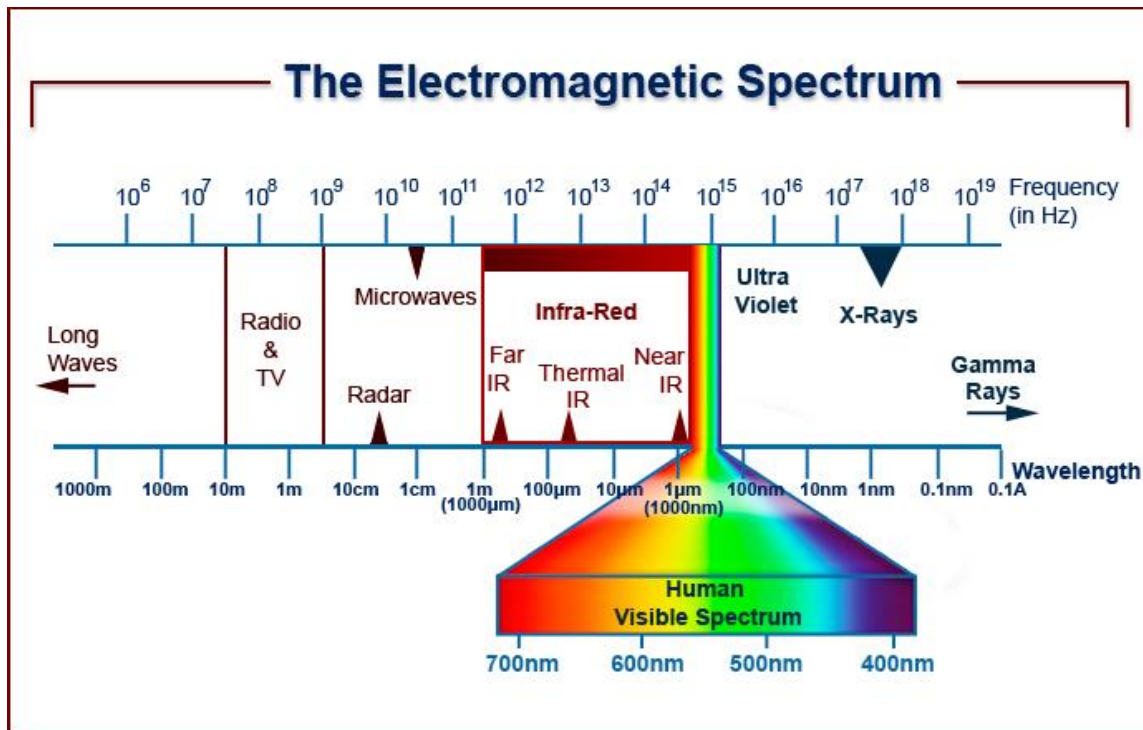

Figure 3.22: This figure demonstrates the electromagnetic spectrum. What is to be illustrated is where the Infrared lies on this scale in comparison with the other wavelength ranges.

Infrared communication operates by using modulation. Modulation varies the waveform of the infrared which establishes a specific command associated to the pattern. When a modulated infrared is sent, it is then received by an infrared LED. The LED is able to detect the modulated infrared, demodulate it, and recognize and perform the task associated with the signal. However there is a flaw to the infrared communication technology, it must maintain a direct connect between the infrared transmitter and the infrared receiver. Direct communication refers to no interference. Inference is any material that is not air that is in the line of sight between the transmitter and receiver. Most people are aware that if there is a person in between the remote controller and the television, the television will not respond. This is a very large consideration for application. Overall infrared is very easy to incorporate in devices and cheap compared to other forms of wireless communication but for a constant form of communication among devices is questionable for use.

3.2.10.3 Zigbee

Zigbee is a new age technology and is the up and coming for wireless communications. Zigbee is a wireless networking protocol and was named after its behavior of zig-zagging between multiple nodes in a mesh network. Just as in Bluetooth and infrared, it is designed for wireless controls and devices. The

devices that the technology is geared toward are those devices that seek low data rates, low power consumption, security, and reliability. Like Bluetooth, Zigbee also operate in the ISM radio bands. Zigbee operates differently, in that there is a singular device that acts as the coordinator, multiple devices that may act as a router, and connected to normal acting devices. Zigbee is able to communicate with devices either directly connected or through other devices connected to a device. Zigbee is able to find the path and establish the connection available. If a node is dropped from the network, then Zigbee searches for another path to the device and establishes a new connection. Zigbee operates with the IEEE 802.15.4 standard. Its known for its ability to be able connect in a Personal Area Network (PAN) like Bluetooth but be free from router based networking, and have an advantage in interoperability. The typical operating distance ranges from 10 meters to 20 meters.

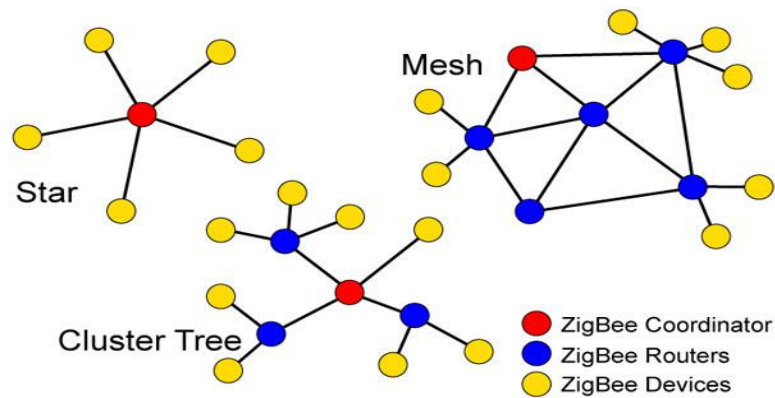

Figure 3.23: This figure demonstrates the different topologies that Zigbee operates with. The three topologies include the Star, Cluster Tree, and the Mesh topology

3.2.10.4 Technology Decision

Wireless communication for our devices is an important aspect of our design. It will allow the scientific data to be transferred directly to an android smartphone. When considering the options for wireless communication technologies, we have to consider all the needs that we ideally envision for our device to operate.

After consideration, we felt Bluetooth was the best wireless communication technology to include for our portable PCR machine. The smartphone compatibility was our largest consideration. Most android smartphones do not already have the infrared capabilities. There are android phones that contain an infrared burst transmitter however even with the technology we still would want to transmit data from our device back to the smartphone. These available smartphones with infrared transmitters do not have infrared LED receivers and thus would not be suitable for our design although would be very cost beneficial.

When data rate and battery life operations are considerations in regard to wireless communication technologies, Zigbee is the best option as it operates with the lowest power consumption which would allow the device to operate for longer periods of time. The data rate is also much slower with Zigbee which is acceptable for our portable PCR machine because the data we our transmitting is relatively small. The data size that Bluetooth transmits exceeds that of our needs. Although Zigbee is the best suited it is not the best option for use.

Bluetooth is readily available in nearly all smartphones today. Zigbee is still an up and coming technology and is not installed in the majority of smartphones today. In order for our device to appeal to a large market we need to assure that a majority of the people have the technology readily available and not be deterred.

After that large consideration, we had to inspect the details of Bluetooth and its suitability. The majority of Bluetooth products are class 2, therefore we will consider class 2. Bluetooth class 2 offers a range within 10 meters. 10 meters is plenty of room for operational use between the portable PCR machine and a smart phone. The average power draw is 2.5 mW for class 2 Bluetooth. This is larger than that of Zigbee but still small enough that it will not affect the battery life of our device dramatically. In terms of communication, Bluetooth is very simple to operate and is still a very good choice.

ZigBee Vs. Bluetooth

	Bluetooth™	ZigBee™
Underlying Standard	802.15.1	802.15.4
Application Focus	Continuous Data Streams, Audio Traffic	Monitoring & Control Data Traffic
Battery Life	Days	Months/Years
Enumeration Latency	Up to 10 sec	30ms
Network Size	7 +1	100s/1000s
Bandwidth (K bits/s)	3000 (EDR)	250
C2 Range (meters)*	10+ (C2)	50+
Network Architecture	Star	Star, Tree, Mesh

Table 3.3: This table shows the comparisons between ZigBee and Bluetooth. These comparisons are necessary for our wireless communication technology selection

3.2.11 Operational Amplifier

An Operational Amplifier is basically a three-terminal device which consists of two high impedance inputs, one called the Inverting Input, marked with a negative or “minus” sign, (-) and the other one called the Non-inverting Input, marked with a positive or “plus” sign (+). The third terminal represents the operational amplifiers output port which can both sink and source either a voltage or a current. In a linear operational amplifier, the output signal is the amplification factor, known as the amplifiers gain (A) multiplied by the value of the input signal and depending on the nature of these input and output signals, there can be four different classifications of operational amplifier gain.

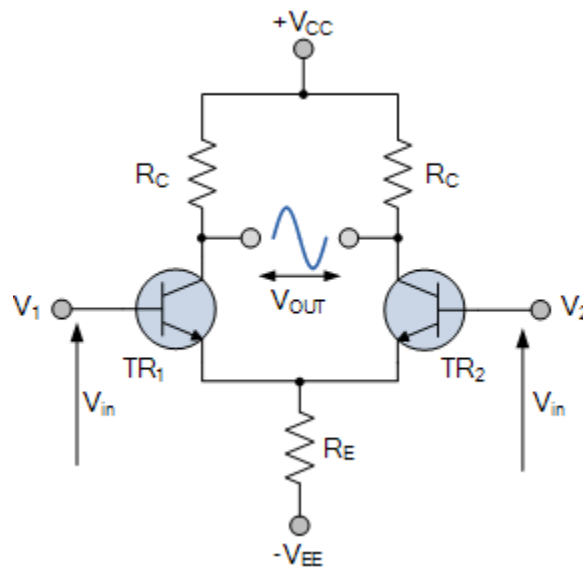

Figure 3.24: Difference amplifier using transistors

The output voltage signal from an Operational Amplifier is the difference between the signals being applied to its two individual inputs. In other words, an op-amp's output signal is the difference between the two input signals as the input stage of an Operational Amplifier is in fact a differential amplifier as shown above in figure 3.24.

The operation characteristics of an operational amplifier are as listed:

Open loop gain: The main function of an operational amplifier is to amplify the input signal and the more open loop gain it has the better. Open-loop gain is the gain of the op-amp without positive or negative feedback and for such an amplifier the gain will be infinite but typical real values range from about 20,000 to 200,000.

Input impedance: Is the ratio of input voltage to input current and is assumed to be infinite to prevent any current flowing from the source supply into the amplifiers input circuitry ($i_{in} = 0$). Real op-amps have input leakage currents from a few pico-amps to a few milli-amps.

Output Impedance: The output impedance of the ideal operational amplifier is assumed to be zero acting as a perfect internal voltage source with no internal resistance so that it can supply as much current as necessary to the load. This internal resistance is effectively in series with the load thereby reducing the output voltage available to the load. Real op-amps have output impedances in the 100-20k Ω range.

Bandwidth: An ideal operational amplifier has an infinite frequency response and can amplify any frequency signal from DC to the highest AC frequencies so it is therefore assumed to have an infinite bandwidth. With real op-amps, the bandwidth is limited by the Gain-Bandwidth product (GB), which is equal to the frequency where the amplifiers gain becomes unity.

Offset Voltage: The amplifiers output will be zero when the voltage difference between the inverting and the non-inverting inputs is zero, the same or when both inputs are grounded. Real op-amps have some amount of output offset voltage.

3.2.12 Touch Screens

Touch screens are growing continuously and becoming a standard as input devices. They allow users to interact with the display directly, rather than using external pointers or buttons. There are two different types of touch screens interfaces. One version of the interface is capacitive and the other is resistive. We will discuss the two different types of interfaces and determine which, if any, would be best suited for the portable PCR machine.

3.2.12.1 Capacitive Touch Screens

Capacitive touch screens uses capacitive coupling to detect any input brought from the user or object. The process of using capacitive coupling for sensing permits the screen to detect any dielectric material that comes in contact with the touch screen. Its sensitivity is established based upon the media of the air. Capacitive touch screens often do not require a physical touch, just as long as the media, air, is weak enough to allow a connection between the two. Since capacitive touch screens operate this way, this allows for more than human hands to operate touch screens, such as a stylus. A stylus was designed to be able to fulfill the dielectric requirement needed to need to operate a capacitive touch screen. This makes the accuracy of a capacitive touch screen very good.

Fingers are very large and bulky, and stylus pens, come in many different sizes. Which allows for better precision, and familiarity as pens are the tool that humans use for writing. However, because of capacitors need for a dielectric for the capacitive coupling, this limits other materials from being able to communicate with the screen. Most of the smart phones today use capacitive touch screens and most users already understand that one cannot wear gloves and operate a touch screen effectively.

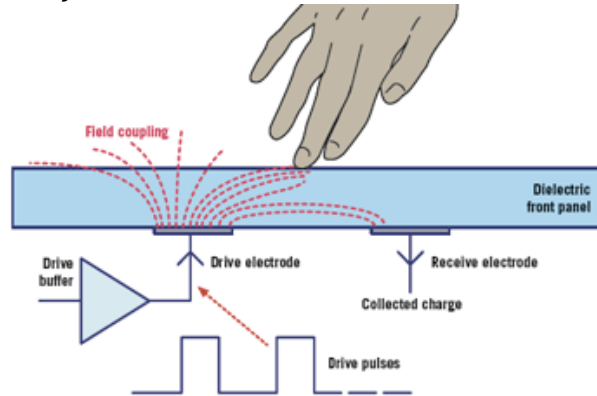

Figure 3.25: Projected capacitive touchscreen. This figure recognizes the capacitive touch screen as explained from above.

3.2.12.2 Resistive Touch screens

Resistive touch screens are different than that of capacitive touch screens. Resistive touch screens operate in separate layers, the first layer is the one that the user can touch. Once this layer is touched, it bends and makes contact with the next layer. The second layer detects the resistance and establishes the location of the touch based upon the resistance. Since resistive touch screens operate in this manner, any material can be used to operate this touch screen, as long as it applies the correct amount of pressure.

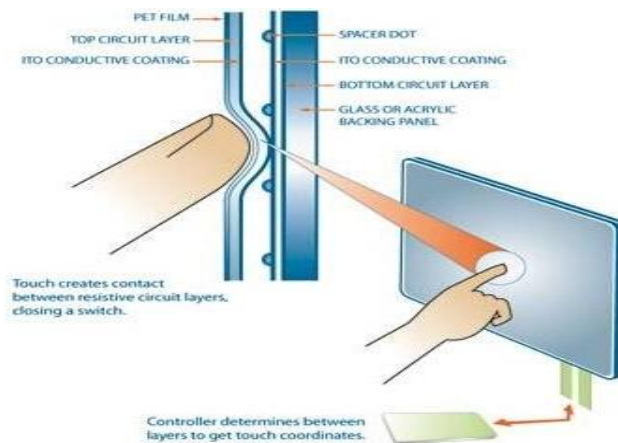

Figure 3.26: This figure depicts the resistive touch screen. Its operation will be used similarly for the touchscreen of our Portable PCR machine.

3.2.12.3 Decision

When considering the portable PCR machine and how we would like it to function in terms of user selection operations, we decided that a resistive touch screen is the best option. Capacitive screens are technically better for precision purposes as a stylus can be very small and still be detected compared to the precision of a resistive screen. However, a requirement that we have is for the user to have the option to be wearing gloves, for their safety in dealing with tests, to be able to operate our device. An all button controlled device was thought of as a practical option, but when it comes to minimizing the size of our portable PCR machine we do not want to sacrifice space to several buttons and have a miniature display that the user will have a hard time seeing. With a resistive touch screen the user will have a much larger screen and still be able to select any option they desire while wearing gloves.

3.3 Strategic Component and Part Selections

This is the section where we will go into depth of the parts that we are selecting and why they will be suitable for our design. We go into each individual design needs and different feature possibilities. Addressing what we feel is best for the portable PCR machine.

3.3.1 Position Tracking

The position tracking technology that we have chosen for our portable PCR machine is GPS. We found having a GPS feature is easy to advertise and provides more useful and important data to our device. We have selected potential GPS modules to compare. We will inspect each of the specifications and determine which of the modules is the best fit for the portable PCR machine. The GPS modules that are being considered is the u-blox NEO-6, the u-blox NEO-7M, and the Adafruit Featherwing.

GPS Module Parts Selection

	NEO-6M	NEO-7M-C	FeatherWing	GP-20U7
Channels:	50 Channels	56 Channels	66 Channels	56 Channels
Power Supply:	3.6 V	3.6 V	3.6 V	3.3 V

Sensitivity	-161dBm	-161 dBm	-145 dBm	-162 dBm
Position Accuracy	2.5 meters	2.5 meters	3 meters	2.5 meters
Acquisition time (Cold Start)	27 seconds	30 seconds	34 seconds	29 seconds
Size:	16.0 x 12.2 x 2.4 mm	16.0 x 12.2 x 2.4 mm	22.9 x 51.2 x 6.7 mm	18.4 x 18.4 x 4 mm
Cost:	\$20.99	\$33.32	\$29.50	\$15.95

Table 3.4: This table compares the GPS modules that are being considered for our portable PCR machine

3.3.1.1 Decision

For our portable PCR machine we have decided to chose the GP-20U7. The GP-20U7 is relatively similar compared to the other modules; such as the power supply, however is it slightly better than the others. The accuracy as well, all being either 2.5 meters or 3 meters. However the device is slightly better in some areas. The cold start time is better than the other modules. The cold start time is considered because we are expecting our device to travel around the world for research. Therefore we are considering its operation under the conditions that it is retrieving data in a distant location from the last reading. The GP-20U7 is great because it has the edge on size, but only on one of the modules. The biggest difference between the modules is the cost. The GP-20U7 is cheaper by five dollars and also performs equally as good as or better than the other two modules. The next best module would be the NEO-6M for the purpose that it has many of the same specifications. This module was slightly more expensive was later determined that it was harder to implement into our PCB.

3.3.2 Operational Amplifier

The operational amplifier (op-amp) is a DC-coupled high-gain electronic voltage amplifier with a differential input and, usually, a single-ended output. An op-amp produces an output potential that is typically hundreds of thousands of times larger than the potential difference between its input terminals. We will be using an opamp to amplify the voltage readings from the photodiodes that determine

the amount of bioluminescence given off by our test. We have chosen to use an op-amp because of its gain of upwards of 10,000 which will allow our ADC to get an accurate reading with relative ease.

3.3.2.1 Decision

Operational Amplifier Part Selection

	MAX406ACSA+	OPA317QDBVRQ1	TSU111IQ1T
SR - Slew Rate:	20 V/us	150 mV/us	2.7 V/ms
Supply Voltage - Min:	2.5 V	5.5 V	5.5 V
Input Voltage Noise Density	150 nV/sqrt Hz	55 nV/sqrt Hz	200 nV/sqrt Hz
Output Type:	Rail to Rail	Rail to Rail	Rail to Rail
Gain Bandwidth Product:	40 kHz	300 kHz	11.5 kHz
Package / Case:	SOIC-8	SOT-23-5	DFN-6

Table 3.5: Operational amplifier selection

For our PCR machine we have chosen to use the MAX406 op-amp due to its very linear gain and low current consumption and very low noise ratio as well as availability and personally having used it for similar purposes previously with exceptional results.

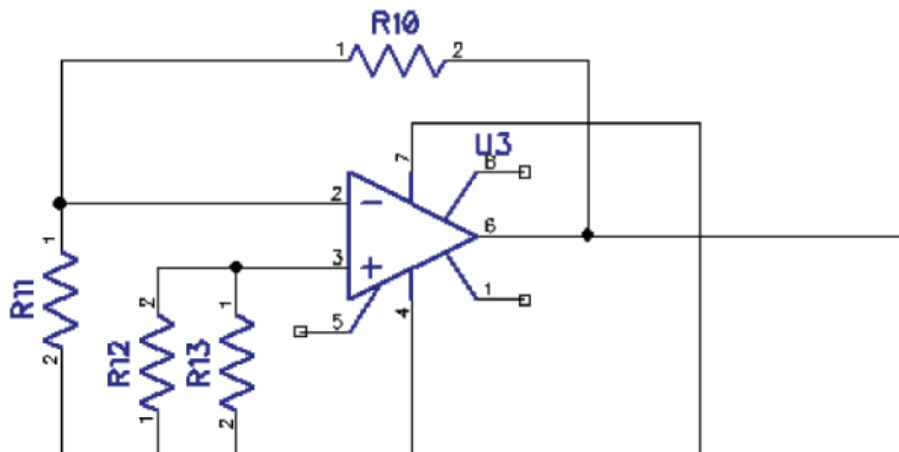

Figure 3.27: Use of MAX406 difference amplifier

3.3.3 MOSFET

A Metal Oxide Semiconductor Field Effect Transistor (MOSFET) is a type of field-effect transistor (FET). It has an insulated gate, whose voltage determines the conductivity of the device. This ability to change conductivity with the amount of applied voltage can be used for amplifying or switching electronic signals. We will be using a MOSFET to control the voltage going into the joule heater and using the Atmega2560 to control the MOSFET device depicted in Figure 3.28.

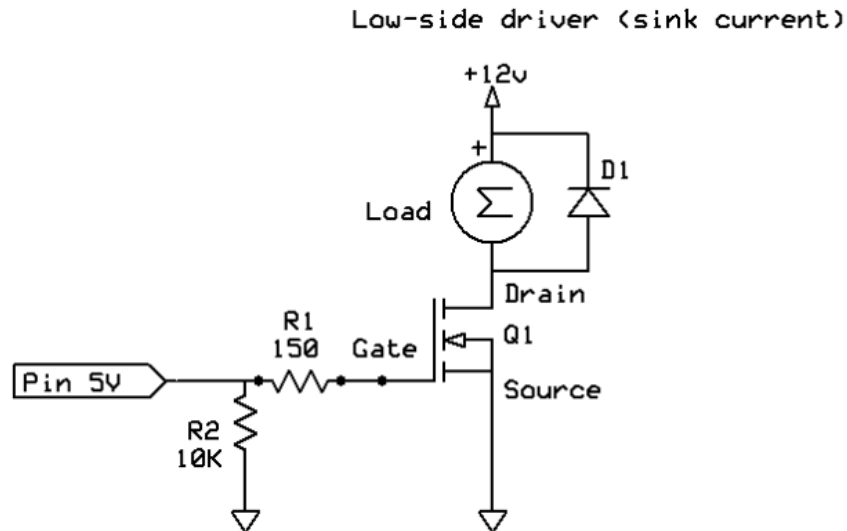

Figure 3.28: schematic diagram of a low-side driver circuit used for sinking current.

The advantages of controlling the joule heater using a MOSFET are that it is easily controllable from a logic level source (Atmega2560) and that the gate pin which controls the flow of voltage across the device requires very little turn on current from the host device (less than 1mA), while delivering a much higher current to a load (10 to 50A or more). The MOSFET we require will need to be able to pass at least 4 Amps of current without heating up significantly and must be able to be directly driven from the Atmega2560.

3.3.3.1 Decision

Knowing these requirements we've selected the PSMN0R9-25YLC made by NXP. This MOSFET comes in a Power-SO8 package which is capable of dissipating 272 Watts. This MOSFET is also capable of a continuous current drain of 100 Amps; which may seem overkill for our application but the cost is low and the specs far exceed most other comparable MOSFETS in the same category listed above. It also has the lowest RDS(on) resistance which means that less power will be wasted as heat making this a much more efficient device.

The major specs considered in our decision were compared and can be seen in table 3.6.

MOSFET Parts Selection

	PSMN0R9-25YLC	DMG7430LFG-7	BUK9Y107-80EX
Id - Continuous Drain Current:	100 A	10.5 A	11.8 A
Rds On - Drain-Source Resistance:	750 uOhms	15 mOhms	89.7 mOhms
Pd - Power Dissipation:	272 W	0.9 W	37 W
Vgs th - Gate-Source Threshold Voltage:	1.41 V	2.5 V	1.7 V
Vds - Drain-Source Breakdown Voltage:	25 V	30 V	15 V
Package / Case:	SOT-669-4	PowerDI3333-8	SOT-669-4

Table 3.6: Comparison of MOSFETS

3.3.4 Temperature Reading Components

In order to make sure the heating elements in our device attain and sustain the desired temperatures we need to be able to read their current temperatures. Using the PID technique we can achieve this but need a feedback device to report the instantaneous temperature of the heating blocks. Ideally we will use a physically small and simple power conservative device to achieve this.

3.3.4.1 Thermocouple

One tool considered for reading the temperature of our heating elements to accurately heat our sample to the desired temperature is the thermocouple. The

thermocoupler would use an effect called the peltier effect where two metals are used as a junction between two temperatures that creates an emf. One temperature is known, known as the cold block, and the other is unknown (the hot block). Through testing, a formula must be conceived that uses the known temperature and the emf read through a voltmeter connected to the circuit created from this set up through calibration. Thermocouples are very accurate at detecting slight temperature changes and delivers rather linear results that could be easily worked with the PID technique our microcontroller will be running to adjust and uphold the temperature. Also, thermocouples can work in a very wide range of temperatures making them great for extreme temperature situations.

3.3.4.2 Thermistor

The thermistor is a tool used to measure the current temperatures of the heating blocks in the PCR machine. Thermistors are just resistors used to measure temperature by measuring the instantaneous resistance. Thermistors are specially designed to drastically change resistance based on slight temperature changes, which makes a quick measurement with an applied voltage and a constant resistance in series. It is a very simple way to find the instantaneous temperature. This can be easily wired to the microcontroller to quickly calculate the temperature to alert the current process in a timely manner. The following formula would need to be included in the microcontroller's program to determine resistance.

$$R = R_c / (1023/V - 1)$$

The variables in the formula are as follows:

R – Variable resistance we are looking for

R_c – a constant known resistance

V – The voltage read across the constant resistor

A constant resistor and the thermistor will be wired in series to the microcontroller that measures the voltage across the constant resistance. With that voltage, we use the formula to calculate the average resistance of the thermistor over 5 cycles to account for the noise of the microcontroller. With that we can calculate the temperature using a simplified version of the Steinhart-Hart equation shown below.

$$\frac{1}{T} = \frac{1}{T_0} + \frac{1}{B} \ln \left(\frac{R}{R_0} \right)$$

The variables in the formula are as followed:

R – Resistance found in thermistor

R_0 - resistance of thermistor at room temperature
B – The coefficient of the thermistor
 T_0 – room temperature
T – The temperature the thermistor is measuring

Using this formula, it is calculated we cannot get much better than a +/- 0.5° C reading. This is not a huge problem and should be pretty accurate using the average value over 5-cycles. We chose to use the thermistor over thermocouples for its often-better precision and lower cost than digital sensors. It is also extremely easy to integrate with the microcontroller and should be very reliable only being a simple resistor.

3.3.4.3 Resistive Temperature Detectors

Another simple common type of temperature detector is the Resistive Temperature Detector (RTD). Very similar to thermistors, these are resistors that change as a function of temperature. The difference is these are usually high-purity conducting metals such as platinum, copper, or nickel wound into a coil. These work on a positive temperature coefficients where thermistors work on negative temperature coefficients. They also give a much more linear output which makes it much easier to read accurate measurements of temperature. Their downside though is that they produce a very small output change with the changes, almost about 1 ohm per degree celsius in most cases. Typical RTD's have a value of 100 ohms at zero degrees and increase to about 140 ohms at 100 degrees.

3.3.4.4 Decision

We will most likely use the thermistor in our final design of the PCR machine. Its small size, less complicated design and implementation, and relative accuracy make it perfect for the task we need completed. The thermocouple in comparison uses a bit more complicated circuitry with a voltmeter and pieces of metal and would need a voltage amplifier that requires more voltage to run. Although the linear results from the thermocouple and RTD would be easier to incorporate, the formula used for the thermistor is pretty simple and we don't need to calibrate with more complicated formulas like what would be needed for the thermocouple. Also, the larger range of temperatures the thermocouples can operate in isn't really necessary for our device which works completely within the range of temperatures the thermistors can work in. The small changes in resistance in the RTDs by comparison make it harder for us to accurately read the small temperature changes we are going to look for to keep our sample heated just right. Table 3.7 compares each part together in a quick visual decision guide.

	Thermistor	RTD	Thermocoupler
Temperature Range	-50°C to 100°C	-260°C to 850°C	-210°C to 1000°C
output type	Non-linear	Linear	Linear
relative cost	Very inexpensive	Expensive	Moderate
size	Very small	Small	Larger
relative complexity	Very simple	Simple	Complex
accuracy	~+/-0.2°C	~+/-0.3°C	~+/-2.2°C
Sensitivity	High	Low	High
Long term stability	Very Stable	Stable	Poorer

Table 3.7: Comparison of average characteristics of temperature detectors

Thermistors are pretty simple parts that work very similarly between the different parts. Table 3.8 shows some comparison between common thermistors used in common heat detection today.

Thermistor Part Selection

	SM103J1K-TR	B57540G104F	NTCLE100E3103HT1
Resistance:	10 kOhms	100 kOhms	10 kOhms
B Parameter:	3892 K	4066 K, 4036 K, 4085 K	3390K
Tolerance:	10 %	1 %	3 %
Temperature Coefficient:	- 4.4 % / C	- 6.7 % / C	-10.3 % / C
Operating Temperature Range:	+ 25 C to + 220 C	- 55 C to + 200 C	- 40 C to + 125 C
Package / Case:	MELF	Through Hole	Through Hole

Table 3.8: Thermistor parts comparison

In our final choice for a thermistor we chose one that is very simple and of smallest size. We chose the mouser NTC 10K ohm Thermistor because of its mass quantities, low price, and simple and tiny design. We will simply need to solder it to a small circuit to the microcontroller to integrate and we are done. This part is extremely popular and can ship up to 2000 at a time so we doubt it will run out of stock.

3.3.5 Power Sources

To power our PCR machine we will need a power source capable of at least providing ~5.5 Amps and a nominal voltage of 3.6 Volts. Many power source technologies are very capable of delivering the power required. Looking at several battery chemistries we have created the comparison table below:

Battery Shape	Chemistry	Nominal Voltage	Rechargeable?
AA, AAA, C, and D	Alkaline or Zinc-carbon	1.5V	No
9V	Alkaline or Zinc-carbon	9V	No
18650	Lithium	3.7V	No
Silver Flat Pack	Lithium Polymer (LiPo)	3.7V	Yes
AA, AAA, C, D (Rechargeable)	NiMH or NiCd	1.2V	Yes
Car battery	Six-cell lead-acid	12.6V	Yes

Table 3.9: Battery comparison

Given the table above, we have chosen to use a lithium type battery as it is widely available and comes in many shapes and sizes and sub sets of chemistry's to suit our needs. There are many types of lithium batteries such as Lithium Cobalt Oxide(LiCoO₂), Lithium Manganese Oxide (LiMn₂O₄), Lithium Nickel Manganese Cobalt Oxide (LiNiMnCoO₂ or NMC), Lithium Iron Phosphate(LiFePO₄), Lithium Nickel Cobalt Aluminum Oxide (LiNiCoAlO₂), and Lithium Titanate (Li₄Ti₅O₁₂). We have made a comparison on the specific energy of each type of respective battery shown below:

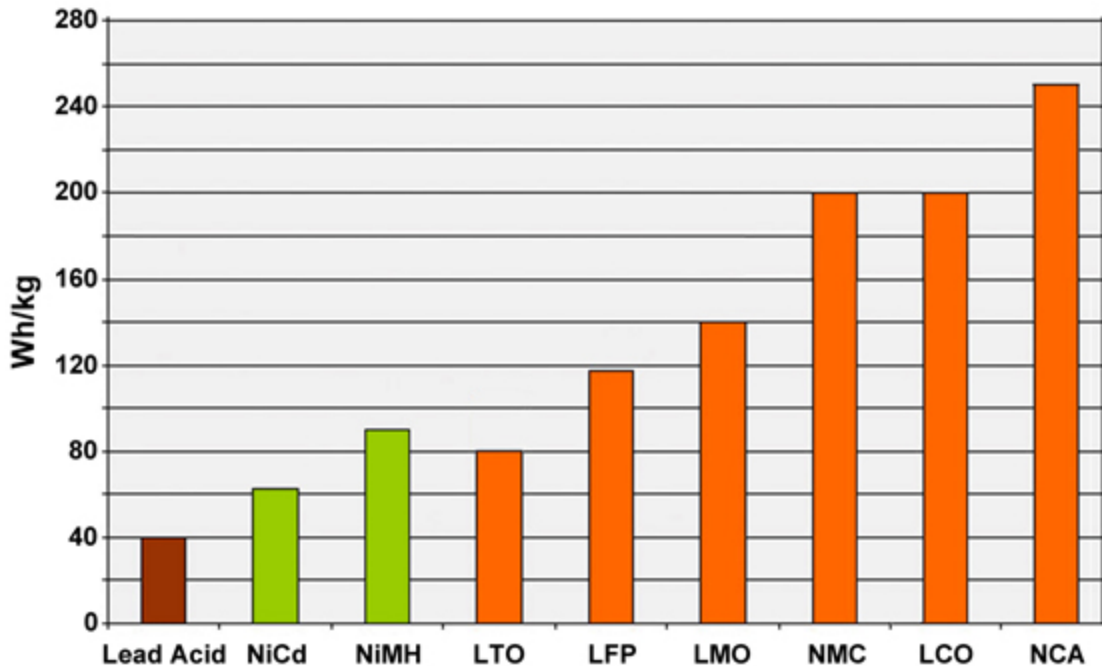

Figure 3.29: Chemistry comparison, specific power.

NCA enjoys the highest specific energy; however, manganese and phosphate are superior in terms of specific power and thermal stability. Li-titanate has the best life span. For the purposes of cost and availability we have chosen to go with a Lithium manganese nickel battery in the form of an 18650 cell. Below we have created a table comparing these 18650 INR battery types:

Battery	Capacity	Comment
Samsung 25R	2500mAh	The standard to which every other 20A battery is compared to
Samsung 30Q	3000mAh	Rated for 15A but can easily handle 20A, equal to the HG2
Sony VTC5	2600mAh	A high performing 20A battery, often counterfeited though
LG HE2	2500mAh	A good performing battery
LG HE4	2500mAh	A great performing battery, about equal to the VTC5
LG HG2	3000mAh	Performs essentially equal to the 30Q

Table 3.10: 18650 LMN battery capacity comparison

3.3.5.1 Decision

Due to the availability of the LG HG2 and price point, we have chosen it as our supply battery. To achieve a long battery life we have chosen to use two of these batteries in parallel giving us a combined capacity of 6 Amp hours. Knowing our capacity we were able to derive an estimated run time of the machine before a full recharge would be needed. Using the formula to calculate power $P = I * V$ and knowing that our nominal voltage is 3.6 Volts and that our max current draw is 20 Watts, we can determine our max average current consumption. Rearranging the formula to calculate for current is as follows $I = W / V$. Using this we know that our current consumption is 5.55 Amps. Using the following formula to calculate battery life (Runtime = Capacity / Consumption) we were able to determine that the PCR machine will have a run time of 1.08 Hours. Which in our application will be more than enough for several tests.

3.3.6 Microcontrollers

The microcontroller is a very important part of the project, responsible for managing all of the major components in the system from moving the servos and joule heating to sending information to an external device wirelessly as well as calculating the concentrations of DNA from sample based on light detected. When considering which microcontroller to use for our project we will first consider what is best for the components we wish to use with it such as the display, servos, external memory, and wireless devices we will use to communicate externally. After, we will consider price and efficiency of the microcontroller taking into account features such as power consumption, memory, clock speed, UART connections, and pin count. Most microcontrollers available today have more than enough pins to accommodate the project's needs so a minimal number is preferable but to start it isn't that important, although we will take into account the analog to digital pin ratio. After some consideration, microcontrollers which seem best for our goals are the ATmega2560, TI CC2640, and the Microchip PIC24FJ32MC104.

3.3.6.1 ATmega2560

The Arduino ATmega2560 seems to be our best bet to start out our project. It is an 8-bit AVR RISC-based microcontroller that can execute powerful instructions in a single clock cycle but does well with balancing power consumption and processing speed efficiently. With more than enough pins at 100 and 4 suitable UART connections it should be able to handle everything our device needs and more. It has 6 flexible timer/counters that can be useful in controlling the many independent components of the device. It also has 32 general purpose registers

which should be more than enough to accommodate the needs of the PCR machines features. The 256K flash memory should be good to hold all the data we need with some extra wiggle room as well. The ATmega2560 is also commonly used with many compatible connections to support a wide range of display shields with a connection that allows the shields to adapt to the voltage provided by the board which would help ease our search for a good compatible display.

3.3.6.2 TI CC2640

We considered the TI CC2640 because it was built to be very effective with Bluetooth systems and is ultralow powered which would give our battery less strain on the MCU and able to focus the power elsewhere. It also costs a lot less and we may still consider trying to use it in the development of the device. TI is a very trusted brand with many features to be added if needed and there are low cost development kits available if needed. The TI uses a 32-bit ARM cortex M3 processor that can also support a 16-bit architecture. It is designed specifically for interfacing external sensors and collecting data autonomously while the rest of the device is in sleep mode. The Bluetooth low energy controller is embedded into the ROM and runs partly on an ARM cortex M0 processor freeing up flash memory for other tasks. It has 128KB of programmable flash memory which is less but should still suffice. One downside is that it only has 1 UART but since it is made especially for Bluetooth connections we hope it could be dedicated to just the display.

3.3.6.3 Microchip PIC24FJ32MC104

The PIC24FJMC104 was considered mostly for its low cost yet high performance. It is a pretty basic 16-bit MCU with no real special features yet all around decent efficient specs. Its flash memory is rather lower in comparison at 32KB and a lower pin count at 44. It supports UART and has flexible clock options and low power modes as well. It is pretty basic, more of a budget option that we chose not to use at first due to the potential for needing more than what it provides as far as memory UART support, and maybe even pin count goes.

3.3.6.4 Decision

After careful consideration, we will use the ATmega2560 to begin development of our PCR machine for its efficiency and room for error and learning. The table seen below (table 3.11) quickly compares some of the main features of the microcontrollers we had considered. After considering power consumption and needs based on these figures the ATmega2560 clearly comes out on top with room to spare. The smaller data size of the instructions make it much more efficient and simpler to run our simple mathematical needs. The larger register supply keeps our options open in the case of many numbers being needed to be

stored as well as the much larger flash memory. The moderate RAM insures a decent cycle time. The amount of pins is sure to be able to accommodate all our features and more if needed and the number of UARTs as mentioned gives us much wiggle room.

	ATmega2560	TI CC2640	PIC24FJ32MC104
Data Size	8 bits	32 bits	16 bits
General Purpose Registers	32	13	16
Clock Rate	16MHz	48MHz	7.37MHz
Flash Mem	256KB	128KB	32KB
RAM	8KB	20KB	2KB
Instruction Set	135 instructions	thumb2 set	84 instructions
CPU Speed	16 MIPS	1.25 DMIPS	16 MIPS
General Purpose I/O Pins	86	31	35
Serial UARTs	4	1	1
Temperature Range	-40 to 85C	-40 to 85C	-40 to 125C

Table 3.11: Table comparing considered features of microcontrollers that we considered

3.3.8 Wireless Communication

We decided to use Bluetooth for our source of communication for the portable PCR machine. Bluetooth as mentioned above was selected because most smartphones have Bluetooth capabilities and we want the largest market available to us, distinguished by this feature. We have hand selected a few Bluetooth modules and compared them to see if they are the best fit for our design and also meet any design constraints that we face.

Our considerable parts are the DSD TECH HC -05, the Jinou CC2564, and XS3868. We will go over the specification of each selected module. After we have

inspected the following parts, we will select the best fitted one and also identify the best alternative in the case that our first selection is not compatible.

Wireless Communication (Bluetooth) Parts Selection

	HC - 05	CC2564	XS3868
Power supply:	1.8 - 3.6V	3.0 - 3.6V	3.6 - 4.2V
Range:	10 meters	10 meters	10 meters
UART Baud Rate:	9600~460800bps	2400~460800bps	115200bps
Size:	12.7mmx27mm	76.2mmx25.4mm	35mmx15mm
Bluetooth	V2.0+EDR	4.1(BR/EDR, BLE)	V2.0
Cost	\$7.99	\$14.99	\$8.29

Table 3.12: This figure compares three Bluetooth modules that are being considered for our design.

3.3.8.1 Decision

Based off of analyzing the components that we have selected we have decided to go with the DSD TECH HC-05. The module fits are design needs in more than one way. Our top priority among comparing these is both power and size. The range with bluetooth modules is very standard at 10 meters and the overall baud rate is manageable, because our device will operate well with any of the given baud rates. We need a small component because we need our device to be as small as possible. From the figure above you can see that the HC-05 has the smallest dimensions and the XS3868 has the second smallest dimensions. The power aspect of each module is important as we want our device to have the longest battery life possible. The HC-05 requires the least amount of power at 1.8 V. The CC2564 comes in second with 3.0 minimum voltage and the XS3868 has the highest power supply of 3.6V. Each bluetooth version is compatible with the versions that are common among smart phones and thus all will suffice this requirement. Although the price difference between the components is very small, every dollar accumulates, so we will still consider the cheapest option which is the HC-05. The HC-05 has the trifecta of power supply, size, and cost; along with

having the necessary capabilities to operate. The second best option would be the XS3868 for its low cost and size.

3.3.9 Photodiodes

To select the ideal photodiode to use in this device, we have selected from several available photodiode on the market that could suit our needs. These choices are shown in table 3.13.

Photodiode Parts Selection			
	ODA-6WB-500M	MTQD5.8PV1-5	SLD-70BG2A
Manufacturer	Opto Diode Corp	Marktech Optoelectronics	Luna Optoelectronics
Passive / Active	Active	Active	Passive
Gain	500M	250M	0
Enhanced Color	Green	Blue/Green	Blue/Green
Active Area	6 mm ²	5.7 mm ²	9 mm ²
Unit Price	\$ 74.42	\$ 24.77	\$ 6.45

Table 3.13: The specifications compared between several photodiodes.

3.3.9.1 Decision

The group has decided to use the ODA-6WB-500M from Opto Diode Corp. This decision was made for a few important factors. The best feature is the integrated amplifier which provides an extremely high gain, more than any of the other options. This will provide an extreme sensitivity that will be vital for accurate detection of fluorescent measurements. The only downside of this device is the cost, however, since the sensitivity is extremely important for this application, the group has decided that the cost is justified.

3.3.10 LEDs

We have decided that the best technology to use for excitation of the samples is the LED. To decide further which LED to use in the project, we have compiled a few choices into table 3.14.

LED Parts Selection			
	MTE4047C5-UB	OD-469L	MTE3047N-UB
Manufacturer	Marktech Optoelectronics	Opto Diode Corp	Marktech Optoelectronics
Size	3 mm	9.4 mm	5mm
Wavelength	470 nm	470 nm	470 nm
Max Current	30 mA	350 mA	50 mA
Unit Price	\$ 7.18	\$ 25.13	\$ 11.42

Table 3.14: The specifications compared between several LEDs.

3.3.10.1 Decision

The group has decided to use the MTE4047C5-UB from Marktech Optoelectronics. This decision was made because of the compact size of the device when compared to others. This is important because the LED will be mounted on the mechanical system that will move. It is therefore important to make certain that the weight on the system is minimized. Another benefit is that the price of the chosen unit is less than comparable devices and that the wavelength of emission is 470 nm which is exactly the required wavelength for the emission dyes. One downside is that the LED only is capable of being driven by 30 milliamps, and will provide less excitation than other more powerful options.

3.3.11 Servomotors

Servomotors will be used to move the mechanical parts of the system. Since a myriad of servos are available in all shapes and sizes, we have done a survey of many different options. The options we have selected are shown in table 3.15.

Servomotor Parts Selection

	SG90	SG51R	HS-35HD
Manufacturer	Tower Pro	Tower Pro	Hitec
Size	23.0 x 12.2 x 29.0 mm	22.0 x 22.0 x 12.0 mm	18.6 x 7.6 x 15.5 mm
Rotation Angle	180 Degree	180 Degree	180 Degree
Weight	9 g	5 g	4.5 g
Unit Price	\$ 2.38	\$ 5.95	\$ 24.95

Table 3.15: The specifications compared between several photodiodes.

3.3.11.1 Decision

We have chosen to use the SG90 servomotors from Tower Pro. This is because they are a reasonably small size which will aid in the compactness of the design but are still priced at a point that is not unreasonably expensive. They are also available in large quantities. Although other servomotors such as the SG51R and HS-35HD are more compact they are almost at a size which is too small to make functional with the tolerances that are able to be produced using 3D printed parts.

3.3.12 Display Screens

Display screens are a very important part of the PCR machine, giving the one source of local input and feedback to the user. We decided on using a touch screen to have the display as easy to read as possible, as buttons would take up space on our ideally small and portable device. Based on our research a resistive touch screen technology does seem to be the best option although other options will be considered just in case.

3.3.12.1 Adafruit 2.8" TFT Touch Shield v2

Adafruit seems to make most of the touch screens most compatible with arduino

microcontrollers so most that we considered are from them. This shield is a basic resistive display screen that is exactly what we need. It uses 4 backlight LCD's and needs only a few pins leaving room for more sensors and components. It is pretty simple plug and run just needing to be soldered on. This shield comes with great support and is a great resolution.

3.3.12.2 Adafruit with Capacitive Touch

This is basically the same screen as considered above but with a capacitive touch screen. This seems to be our best bet if a resistive screen proves to be inefficient or troublesome. It comes with the same features as the one above and if a switch is needed the same libraries and communications would be used, keeping a switch an almost seamless process

3.3.12.3 Adafruit 2.8" TFT LCD B/O Board w/microSD

This touch screen is also very similar to the two above but with a few extra features and a microSD for local storage. This is very important to us because we were looking for a local storage device, and to have it conveniently connected with our LCD screen would be perfect. This also comes with a built in RAM for buffering so the microcontroller doesn't have to devote as much computing power to the display. It is also well supported with libraries to assist in working the board as well. The shield we decided on also supports a higher voltage which makes it easier to deal with in case of compatibility with the microcontroller. Comparisons between the three can be seen in 3.16.

	Adafruit TFT Touch Shield v2	Capacitive	With microSD
Voltage Compatability	Up to 3.3V	Up to 3.3V	Up to 5V
Pins	13	13	12
Color	18-bit	18-bit	8-bit
Resolution (pixels)	240x320	240x320	240x320
Size (Diagonal)	2.8"	2.8"	2.8"

Table 3.16: Comparison of main features of LCD shields

3.3.12.4 Decision

Although it comes with a few more pin attachments and is a bit more complicated, the screen with the microSD is what we agreed upon for its many benefits that outweigh its downsides. Although it may be a little more difficult to switch out if we decide to switch to capacitive, the decision between the two doesn't usually have much effect on overall processes. The libraries are also rather similar, just the pinouts would need to be reworked a bit differently. The first screen delivered is also still a great viable candidate, but the extra RAM and microSD on the other was what really drove us to make our final decision and are confident it will prove best.

3.4 Parts Selection Summary

To make progress in the design process for this project, a number of parts were ordered as shown by figure 3.30 and table 3.17 below. Component **A** is an important example relevant to this project, as it shows a set of 3D printed gears. 3D printing will be used to produce and construct all of the components in the design that are not purchased, as a result, most of the parts will be 3D printed in the final product. The gears are shown to represent these parts which will be designed. **B** is an example of the heating elements. This part is made from an aluminum rod and is wrapped with polyimide tape for insulation and NiCr resistance wire to form the heat source. **C** is the NiCr resistance wire which will be used to construct the heating elements. **D** is an Arduino Uno, which is a development board which contains an ATmega328 microcontroller and will be used in the breadboard phase of this project to control all of the electronic components until a custom PCB is designed. **E** are the thermistors that will be used to determine the temperature of the heating elements. **F** is the photodiode that will be used for the detection of the fluorescent emission from the samples. **G** are the blue LEDs that will be the source of light for the excitation of the fluorescent probes in the sample. **H** are the optical filters used to eliminate crosstalk between the excitation and emission wavelengths of light in the optical system. **I** is the LCD display and touchscreen assembly which will be used for user input and output in order to operate the device. **J** are the servomotors which will form the basis of the mechanical system that will move the PCR tube between heating and cooling elements. **K** is the GPS module which contains the GPS antenna and GPS radio used to communicate with GPS satellites to determine the device's location on the surface of Earth. **L** is the Bluetooth module that will be used to communicate with a smartphone for the data logging and analysis smartphone application. **M** are MOSFETS that will be used to enable and disable the heating elements, providing temperature control. **N** are the operational amplifiers that will be used to amplify the signal from the photodiode as well as remove the signal offset before being sent to the microcontroller.

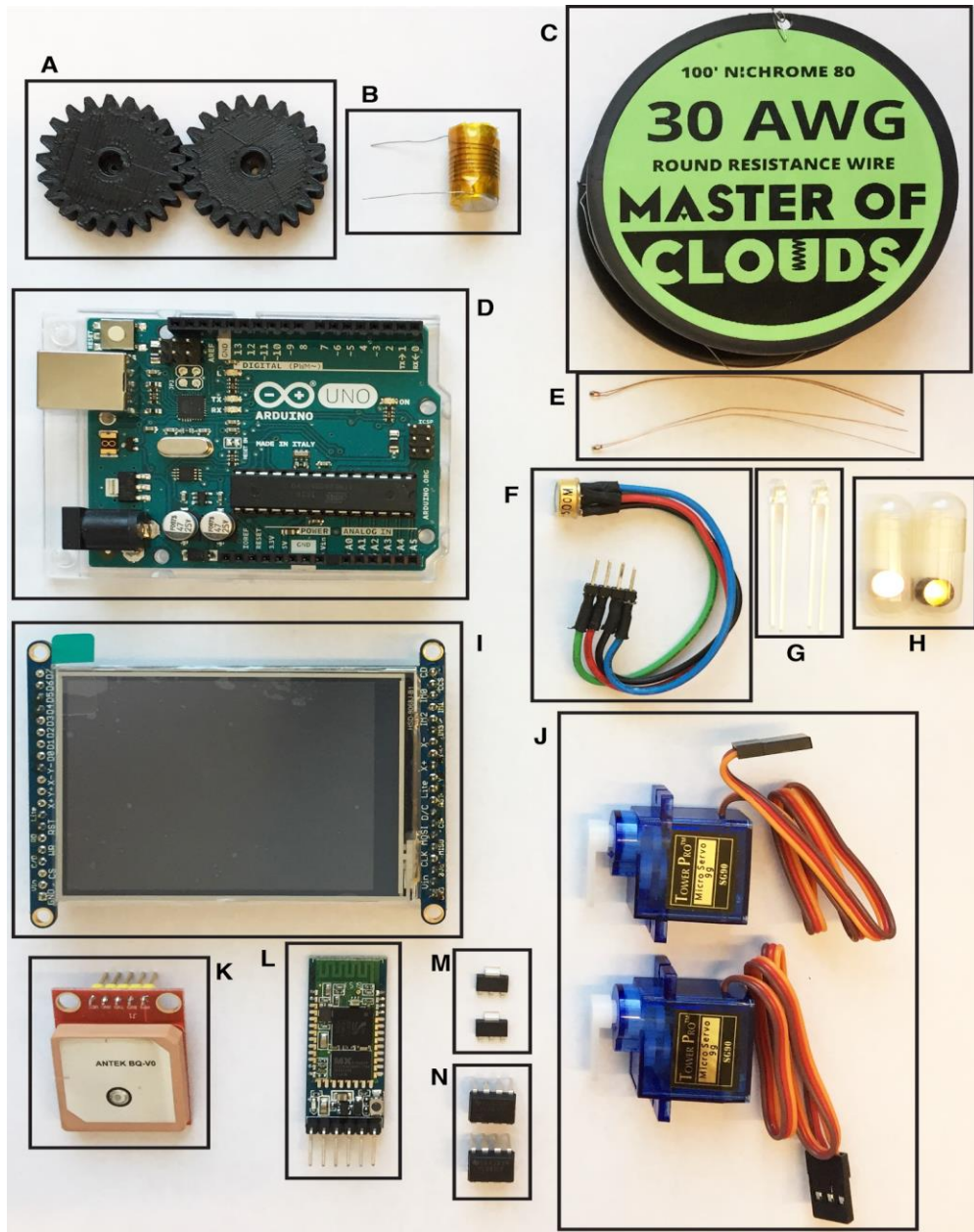

Figure 3.30: Components and parts ordered for the PCR device.

Part	Description	Source	Price
A: 3D-printed components	A representation of the various 3D printed parts that will be used in the device	Manufactured by 3D printer	Varies based on size of part
B: Heating / Cooling element	Used for heating and cooling	Manufactured	~ \$ 1.00
C: NiCr wire	Used for heating element	Amazon	\$ 5.99
D: Arduino Uno	Used for electronic control	Amazon	\$ 21.99
E: Thermistors	Used to measure temperature	Amazon	~ \$ 0.80
F: Photodiode	Extremely sensitive photodiode used in fluorescent measurement	Mouser Electronics	\$ 74.42
G: LEDs	Blue excitation LEDs	Mouser Electronics	~ \$ 0.30
H: Optical Filters	Used to eliminate Crosstalk	Omega Optical	~ \$ 50.00
I: LCD and Touchscreen	User Interface	Amazon	~ \$ 30.00
J: Servo Motors	Used to control mechanical components	Amazon	~ \$ 2.00
K: GPS Module	Used to determine location	Amazon	\$ 20.99
L: Bluetooth Module	Used to communicate with smartphone application	Amazon	\$ 7.99
M: MOSFET	Used for heater control	Mouser Electronics	\$ 2.00
N: Op-amps	Used to amplify fluorescence reading	Mouser Electronics	~ \$ 1.00

Table 3.17: The list of parts ordered and shown in the figure above.

4 Related Standards and Realistic Design Constraints

However unique or common a device may be, every device is designed with the standards set forth either globally or nationally in mind. Standards help guide designers ensure safety, reliability, productivity, and efficiency. Standards develop a uniform method with thought out written procedures, although not mandatory, they help guide engineers. Standards are considerations when developing a project. Design constraints are factors that determine many of the limitations of the device. We will begin to discuss more of the the standards and constraints in further detail.

4.1 Standards

Standards are generally thought of as a set of technical definitions and guidelines. Many of the standards today are made by generated by the American Society of Mechanical engineers or ASME. Although there are many more organizations that help identify technical standards. Standards help engineers understand base protocols and methods that other engineers can reference.

4.1.1 Health Insurance Portability and Accountability Act (HIPAA) Compliance

Since our device is transmitting medical data that pertains to identifiable individuals we must take into consideration the Health Insurance Portability and Accountability Act (HIPAA). The Health Insurance Portability and Accountability Act of 1996 (HIPAA) required the Secretary of the U.S. Department of Health and Human Services (HHS) to develop regulations protecting the privacy and security of certain health information.¹ To fulfill this requirement, HHS published what are commonly known as the HIPAA Privacy Rule and the HIPAA Security Rule. The Privacy Rule, or Standards for Privacy of Individually Identifiable Health Information, establishes national standards for the protection of certain health information. The Security Standards for the Protection of Electronic Protected Health Information (the Security Rule) establish a national set of security standards for protecting certain health information that is held or transferred in electronic form. The Security Rule operationalizes the protections contained in the Privacy Rule by addressing the technical and non-technical safeguards that organizations called “covered entities” must put in place to secure individuals’ “electronic protected health information” (e-PHI). Within HHS, the Office for Civil Rights (OCR) has responsibility for enforcing the Privacy and Security Rules with

voluntary compliance activities and civil money penalties.

For the purposes of this paper I will generalize the HIPAA act. Our project will be concerned with the following information:

- Name, address, birthdate and Social Security Number;
- An individual's physical or mental health condition;
- Any care provided to an individual; or
- Information concerning the payment for the care provided to the individual that identifies the patient, or if there is a reasonable basis to believe it can be used to identify the patient.

For the reasons of time constraints and cost, we have decided to anonymize our data that we will collect from testing. Anonymizing our data that we will collect will prevent us from having to comply with the HIPAA act. We will only collect a patient's age, sex, and race.

4.1.2 IP Standard

The environment which this board may encounter and should be able to withstand consist of a humidity greater than 90%, shocks greater than 2 G's, and dust/dirt debris. Given these environmental hazards the board shall comply with the International Protection Rating (IP Rating) as defined by the National Electrical Manufacturers Association (NEMA). This rating defines the degrees of protection provided by enclosures. The standards are shown below in Table 4.1.

Given our specifications below, we have decided that an IP rating of IP 63 would be acceptable given our application and design constraints. That being said if the PCB is to follow these ratings and not fail under these conditions then the batteries which will supply the power must also adhere to these ratings as well. The 18650 lithium-ion batteries come in a sealed form factor but that does not inherently mean that they are IP 63 compliant. This will be further discussed in down below in the hardware testing section.

4.1.3 FR-4 PCB

The goal of this Polymerase Chain Reaction (PCR) Printed Circuit Board (PCB) is to give this project reliable functionality with minimum cost while retaining a quality that does withstand the environment that it may encounter. The PCB will encompass and control most critical functions of the project; which include charging, electromechanical controls (servo's), temperature sensing, joule heating control, user interface, and communications to other devices. The circuit board itself will be the NEMA defined standard FR-4 fiberglass board specification are

shown below in Table 4.2.

IP Rating Chart			
First Number	Definition	Second Number	Definition
<i>Protection against solid objects</i>		<i>Protection against liquids</i>	
0	No protection	0	No protection
1	Protected against solid objects over 50mm (e.g. accidental touch by hands)	1	Protected against vertically falling drops of water
2	Protected against solid objects over 12mm (e.g. fingers)	2	Protected against direct sprays up to 15° from the vertical
3	Protected against solid objects over 2.5mm (e.g. tools and wires)	3	Protected against direct sprays up to 60° from vertical
4	Protected against solid objects over 1mm (e.g. tools, wires and small wires)	4	Protected against sprays from all directions - limited ingress permitted
5	Protected against dust - limited ingress (no harmful deposit)	5	Protected against low pressure jets if water from all directions - limited ingress permitted
6	Totally protected against dust	6	Protected against strong jets of water (e.g. for use on shipdecks - limited ingress permitted)
		7	Protected against the effects of temporary immersion between 15cm and 1m. Duration of test 30 min.
		8	Protected against long periods of immersion under pressure

Table 4.1: IP rating chart, showing the various classifications of the IP rating system.

Parameter	Value
Specific gravity/density	1.850 g/cm ³ (3,118 lb/cu yd)
Water absorption	-0.125 in < 0.10%
Temperature index	140 °C (284 °F)
Thermal conductivity, through-plane	0.29 W/(m-K), ^[1] 0.343 W/(m-K) ^[2]
Thermal conductivity, in-plane	0.81 W/(m-K), ^[1] 1.059 W/(m-K) ^[2]

Table 4.2: Specifications of FR-4 fiberglass circuit board material.

As seen above these boards are fire resistant which is important to our project since large amounts of current will be dissipated generating large amounts of heat. These boards will also be a standard one ounce copper pour which will also allow us to transmit large amounts of current, while also dissipating it into the copper plane. The entirety of the circuit board with copper pour and FR-4 Fiberglass material is shown below in Figure 4.1, demonstrating the FR-4 Fiberglass material in green sandwiched between the upper copper layer and lower copper layer shown in yellow.

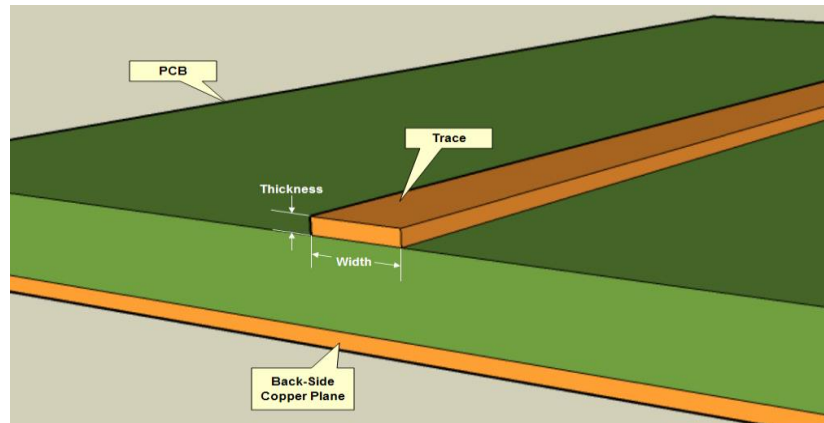

Figure 4.1: Structure of FR-4 fiberglass circuit board.

4.2 Realistic Design Constraints

Our design like any other design is not only governed by the feasibility or usefulness as a product to consumers, but is also affected by many other factors. Factors that incorporate our design and the world, or the product and the market. It is impossible to design a product as well without these factors, for they are not considerations but components that attribute a design's value. The most notable constraint is the finances, as every engineer or entrepreneur realizes this after the very idea of the design is given birth. The other constraints such as time, environmental, social, political, ethical, health, safety, manufacturability, and sustainability are crucial to any design and thus will be discussed in more detail.

4.2.1 Economic and Time Constraints

The most common restraints of design outside a product being feasible and useful is both economics and time. Economics is generally thought of as money, or cost of the production of the product. Although those are factors that are associated with economics, that is a false assumption. Economics identifies the market and how it behaves. When a product is the focus within the market, it allows the designer to view a full scope of how to approach the design. The cost is, of

course, how much money the product requires to be produced. Let's go into detail about this first.

All designs all have a similar goal of minimizing their cost. Of course, this is to be able to generate the greatest amount of profit. Profit is acquired when the cost is subtracted from the price of which it is sold, also known as the market price. However, where these cost are coming from is variant. Material costs is one form. All of the materials we select, go through the process of establishing if it is the best option for our design and then followed by questioning if the cost of the material is practical for the design use. Sometimes the best material for a device may be ideal, say if it were light and durable, but may not be used because of its expense. The selection is based upon comparing, what is sometimes thought of mixing qualitative and quantitative value, the materials design value, in terms of suitability for the device, over the materials price. This ratio although isn't officially done on paper most of the time, it is always thought about in the decision process. Often a device, will incorporate each individual component and follow the same protocol of analysis. Features are a different scenario. Features are looked at as a way to increase the value of the product and thus has to take a different approach of analysis, but only in a minor sense. It takes the expected increase of profit generated from the feature and subtracts that of the features implementation cost.

Our goal for our project is to design a portable PCR machine that will also have many features for data purposes. Our project is being sponsored and our limit for constructing the device is five hundred dollars. This is a very generous amount to work with when constructing our device, however it is always beneficial to design a product that will generate the lowest cost. Also if our device were to go on the market, generating a low cost would be ideal.

Time is a very crucial factor upon our device. We must be able to construct, test, and fully assure that our design will function properly by end of the 2017 UCF summer session C semester. This affects the project as decisions, research, implementation, design, and troubleshooting all must happen at a reasonable scale. If this design had a larger time scale, the design has a higher chance of design optimization, such as if it had a shorter time scale, it would most likely lack in the end result relatively. To combat this restraint, we have organized a group chat, where any of the group members can contact each other at any time to discuss details. Along with that, we have established official meeting times that fit the schedules of all the team members. We have also created a Google Drive folder with all the content being shared by all the members. This allows for every member to have access to any file that each member shares. Technology helps contribute to combat the time scale.

4.2.2 Environmental, Social, and Political Constraints

Having a quick and efficient and extremely portable and connected PCR machine seems like a completely pure and positive development but there are a few constraints we need to adhere to for the final design of our project. Products that will be working with any type of potentially hazardous biological material always need to be carefully designed with many factors considered. Also, the widespread use and distribution of patients' personal information needs to be considered as well as how the information gathered may affect an individual or group of people.

Environmental factors that need to be considered are mostly related to the materials used to make and continue the function of the product. The machine is designed to use a sterile standard PCR tube to reduce potential contamination of individuals working with the sample as well as the machine and even get the best reading of the sample in the device possible. The use of this product already in production means there is no need to waste resources creating specially designed containers to work with the device. The outer shell is also designed to be simply made with a 3D printed material that can be found at ease reducing the need for use of any scarce natural resources. The battery on our device is quite a concern as it may take a lot of energy to heat and cool our sample and keep the device from overheating at the same time and damaging surroundings or individuals nearby. To keep it as environmentally friendly as possible as well as useable in more remote areas a small solar panel will be on the device to help keep up a charge using renewable energy.

One aim of the portable PCR machine is to record data from even the most remote areas and record the findings there on a server through a wireless device for further analysis, mostly regionally to track diseases and their development. This obviously could be an infringement among patients' privacy rights as their personal information is sent to the database. To work around this the device does not necessarily have to be connected to an external device that will broadcast their information to work. Even if it is, we will probably have to ask the user to accept to terms of use and/or their personal information be kept anonymous, simply sending broad information like general location and age as well as the results.

Results from a PCR machine becoming much more affordable and easily accessible could expose problems in areas not known as much before and could really help societies to learn that they may need to take action to prevent serious outbreaks but could also hurt the reputation of those areas or individuals. The idea could bring about debates such as whether information such as HIV/AIDs status should be made public or not based on safety concerns versus social

privacy rights. Some argue the public release of the information could seriously help protect many from the unwanted spreading of diseases while others argue it is a serious violation of privacy that could set precedents for similar infringements on basic civil rights. To avoid this issue, the solution above seems the best, only recording and sharing very general information and leaving the further release of any information up to the patient or user.

Another factor to consider when testing a wide array of participants is the differences in cultural and social situations that are always changing. One interesting example that could affect the design features especially when recording the data from the test is sexual orientation and/or gender identity. Different identities in this ever-evolving day and age have already shown specific trends related to their orientation or identity. Not only could their identity in that area help identify trends but could also change the way we might want to make the options for a simple form.

In a social form, having only the option to identify yourself as exclusively male or female could actually anger or confuse certain subjects. Angering a patient could lead to a significant impact on participants that actually share the information with our planned database and we could miss out on some very important statistics to study. The question of what to put exactly for gender options is a tough one, as some may identify themselves as male while biologically being female and vice versa while still others may just say they identify as neither. Some may have been born biologically as a female and have chosen to go through surgery and take hormones to become much like men. The variety of identities these days could seriously affect our studies as figure 4.2 from a survey of how many people in a sample of STEM careers shows just how many people of different sexual orientations (the different colors representing what they are attracted to based on their identity) identity as different genders (the totals being the numbers at the end of each column).

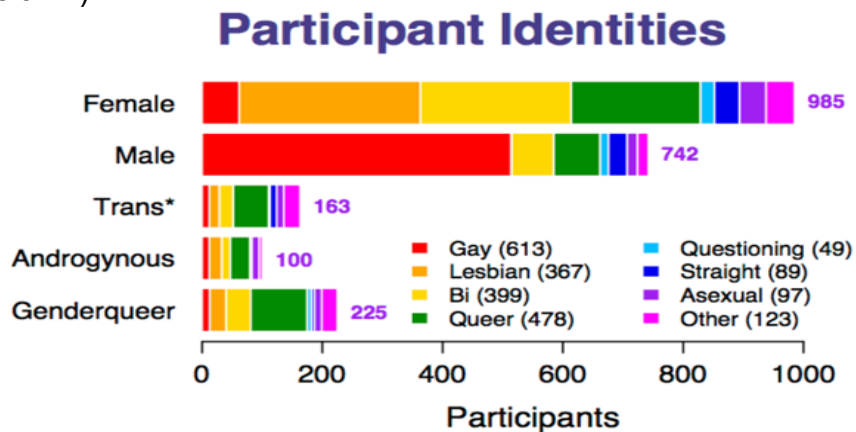

Figure 4.2: Survey of STEM career personnel on their sexual identity based on sexual orientation.

The inclusion of different gender identities could be a huge advantage to our product as well. Studies have already shown that transgender females have some of the highest rates of HIV infections but not much is known about transgender males. Further documentation and analysis could help develop real strategies for prevention and treatment. Research in this area is still greatly needed and our product could seriously help further the studies in this area. Transgender may therefore be a good option to include in our options because disease may actually act differently in conjunction with hormones taken or behaviors and even genetic differences in them based on whether they are male to female or female to male so specification in that regard may be needed. On the other hand, people who consider themselves as genderqueer or androgynous, simply having no identity as either male or female or even just considering themselves different from what they biologically are, could mess with important medical results. If one wishes to say they are female because they feel that way but are actually biologically male this may cause some problems. For this we may just ask to specify what gender you are biologically or just keep an “other” option.

4.2.3 Ethical, Health, and Safety Constraints

To prepare samples for tests, the biosafety laboratory environment at the Burnett School of Biomedical Sciences at the Lake Nona campus will be required. To truly test that the machine is functional it will be necessary to test it using a virus. As such, there is some risk involved in preparation of the samples and care must be taken in both the choice of the virus used for testing as well as the containment of the virus used. With the advice of Dr. Kim, the virus this group will use for testing purposes is Lentivirus. Lentivirus is a family of viruses that contains HIV. Because of this, if the device is able to confirm the presence of Lentivirus, then the device will be able to detect the presence of HIV as well. However, since Lentivirus contains many different viruses in the family, a specific virus can be chosen that does not have as dramatic consequences to the individual preparing the samples as HIV would. Because of these details, we have chosen to test the device using SOX2. This is a virus in the Lentivirus family that only affects a mouse, so no harm will fall upon the human group members in testing the device. Additionally, if anything involved in the experiments should come in contact with the samples that is not intended, the worst case scenario will only affect mice.

4.2.4 Manufacturability and Sustainability Constraints

The ideal lifespan of this PCR machine will be at a minimum of one year, 365 days, of continuous use at an estimated 10 test cycles per day. Meaning this machine will undergo 3,650 cycles before any of the parts will give up. This is a highly derated value though due to its extreme environment it will be possibly seeing.

The first parts to fail will more than likely be the electromechanical servo motors as they are meant for hobby use and not meant to see such a continuous use. We can circumvent this by using industrial servo motors from Dynamixel (Figure 4.3), but that would be at a great cost as it would increase the size of the machine, weight, and cost by a large amount.



Figure 4.3: Industrial servomotor.

The electrical components are all rated for a minimum of 10,000 cycles before any such failure is to occur. So they will long outlast any of the other physical components on the machine itself.

5 Project Hardware and Software Design Details

Design is an important process required to produce a final product. As such much effort has been placed into the design of systems for the device. In this chapter, we will describe in detail the elements that have been designed for the project.

5.1 Heating and Cooling

The process of PCR relies on the thermal cycling of a sample between approximately 60 and 95 degrees Celsius. When the sample is at 95 degrees, the DNA in the sample is split into its two strands. The sample is then cooled to 60 degrees where the polymerase in the sample begins to reconstruct the opposite half of the DNA strands, the entire thermal cycle results in a doubling of the quantity of DNA in the sample. When repeating this thermal cycle 40 times, the amount of DNA in the sample effectively increases 2^{40} times. This amplification is the means by which PCR has become the industry standard in viral detection because it allows for the easy detection of the virus concentration. For example, if there is one segment of HIV virus DNA in the sample at the beginning of the process, there will be more than one trillion copies of that DNA at the end. This massive quantity of DNA at the end of the process is much more easily detected than a single segment and the primary reason PCR has become the industry standard. Since temperature cycling is perhaps the core element of PCR, it is necessary to design a quality heating and cooling system. There are a myriad of different ways to create a system that does this but since the final qPCR machine is designed to be operated on batteries, the most efficient system will be ideal. Because of this, Joule heating is the ideal technology to use in the device. Another important fact to note is that because of the temperatures involved in the PCR process, between 60 and 95 degrees celsius, the term “cooling” actually refers to 60 degrees celsius, which is above the ambient temperature of ~ 23 degrees celsius. Because of this fact, the process of Joule heating will actually be used for heating and “cooling” the sample.

5.1.1 Heating Element Design

In order to realize a practical heating element, some mechanical properties must be taken into consideration. Firstly, the materials used must be available and easily manufactured. For example, arbitrary sizes of raw materials should be avoided because they are usually available in standard sizes. Because of this, aluminum rod with a diameter of $\frac{3}{8}$ inch was chosen to form the main body of the heating element because it is small enough to allow for the device to stay small,

but large enough for the PCR tube to fit inside. The basic structure of the device consists of a short section of the aluminum rod wrapped with NiCr wire that will provide heat to the rod by Joule heating. This structure is shown in Figure 5.1. The length of the rod, 0.75 inches, was chosen so that there would be enough space to wrap several turns of the NiCr wire around the rod without shorting out between turns, while still being compact. Temperature feedback will be provided to the microcontroller using a thermistor attached to the aluminum rod. The temperature of the rod will be controlled by the microcontroller and a MOSFET using a PID feedback system for an accurate and stable temperature. Another critical feature of the heating element is the ability for a quality contact with tube. This will be discussed in the following section.

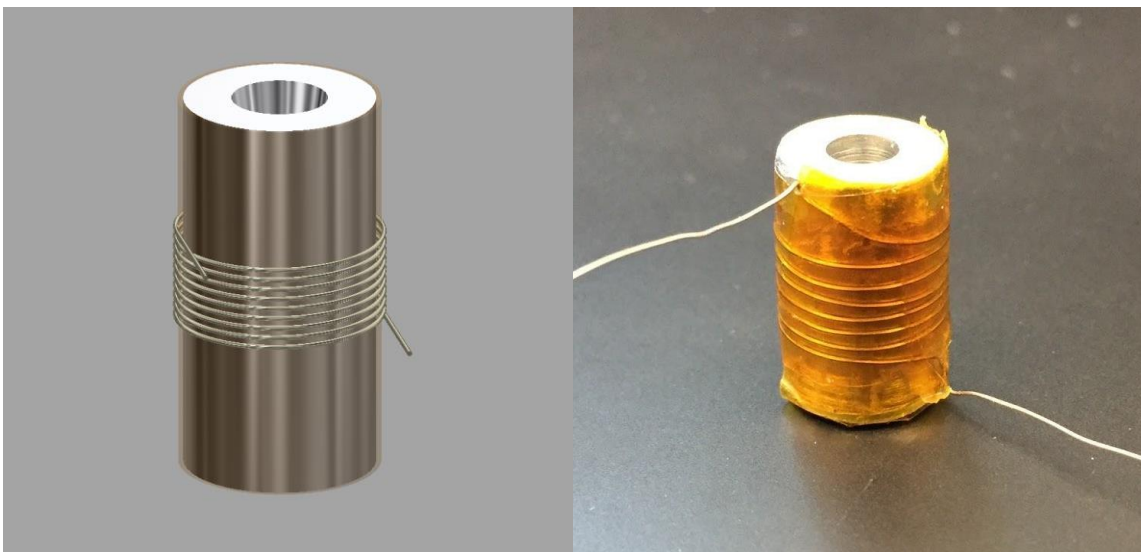

Figure 5.1: Left: The heating element as designed in Inventor. Right: The heating element as constructed using NiCr wire.

There are many ways to heat the PCR sample tube to our specified temperature, each with their respective pro's and con's. Some materials we came across during our research are Nichrome wire which is an alloy composed 80% nickel and 20% chromium. This wire has a very specific resistance per inch, making it easier to calculate the amount needed. It's also corrosion resistant which is more than ideal given our application will be in an outdoor environment realistically. Nichrome can also withstand temperatures of up to 1,400 C. Which is well beyond our operating temperatures, which are upwards of 70 C. This massive temperature difference would ensure a very long operation life, and make this this most unlikely failure source in the project. There are very similar products such as kanthal, which is another alloy composed of mainly iron, chromium (20–30%) and aluminium (4–7.5 %).



Figure 5.2: Kanthal heating element example

Our research also lead us into just using copper as our heating element. It has a very predictable resistivity, dependant on temperature, which we can take into account. They can be designed to any specification desired and easily custom manufactured. This copper heating element is actually a one ounce per cubic in copper pour, adhered to a flexible piece of Kapton tape (polyimide tape). This is the factor that gives an advantage over everything else; since it's flexible it can wrap around any surface, but yet stay together since it's adhered to the tape, unlike nichrome or kanthal which is susceptible to sliding up or down the PCR heating element tube when touched or moved.



Figure 5.3: Kapton heating element

Since this is essentially a circuit board, we can design using KiCAD our exact custom design on a 2d plane to wrap around the PCR tube holding apparatus. Our preliminary design is shown below.

To get this design we measured the diameter and height of the PCR sample tube holder which we then calculated the circumference and laid out the physical dimensions flattened out in 2D as seen above, the white lines being the border of our actual physical dimensions.

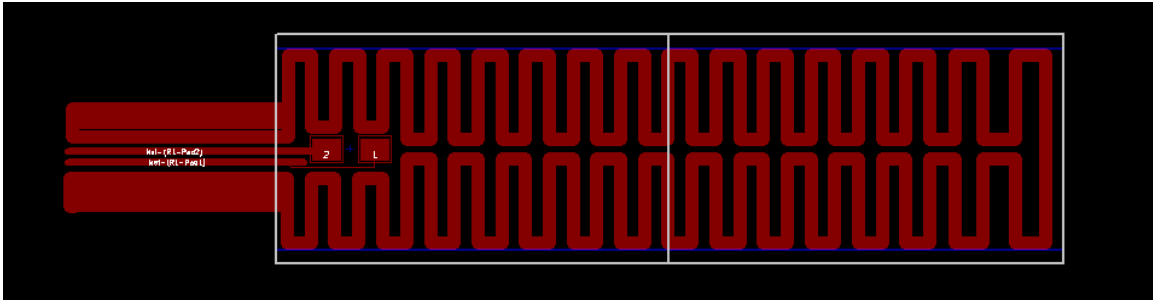

Figure 5.4: Kapton heating element design in KiCAD

Then using the formulas below we calculated the exact length of wire needed and at what width was required to get a resistance that would dissipate our estimated 20 watts of continuous power.

$$W^2 = \left(\frac{L}{k} * R \right)^{1/2}$$

Trace Width Formula

$$L = \frac{W^2}{R} * 1.378$$

Trace Length Formula

$k = 0.048, b = 0.44, c = 0.725$ (As defined by IPC-2221)

Using these formulas we derived that we will need a trace of one millimeter and a length of 500 millimeters giving us resistance of .24 ohms at room temperature and a resistance of .43 ohms at a max temperature of 230 C (initial fast heating of PCR apparatus). This in turn, with a nominal input voltage of 3.3 Volts gives us a maximum power output of 45 watts, which is largely over our nominal power output, but will be used on initial heating to speed up the PCR process and will be dialed back in the software after the initial cycle period.

5.2 Optical Design

Besides the thermocycling, the most important system of a qPCR device is the ability to quantify the amount of target DNA present in the sample. This feature is what differentiates a qPCR machine from a standard PCR thermocycler. There are a number of ways to determine the target concentration, including electrochemical systems, however the most widespread and effective method is one which relies on optics. The method works by placing a specific primer into the PCR sample. When bonded to DNA, this primer fluoresces if excited by a particular wavelength of light and emits light on another wavelength. In physical implementations of a fluorescent detection system, the sample is excited by an LED or laser usually passed through an optical bandpass filter. This is so the excitation occurs on the exact wavelength required by the specific primer. The system then observes the sample using a photodiode or similar detector behind another optical bandpass filter centered on the specific wavelength emitted by

the primer. Since the primer will only bond to a specific sequence of DNA, a PCR system equipped with a fluorescent detection system can be extremely sensitive at measuring very specific target DNA. Since the primers can be designed to bond to any sequence of DNA, a primer can be made that will bond to a sequence only found in a virus, such as HIV. Using this feature, a PCR device can be made to search for and detect any virus present in a sample, thus allowing for accurate and reliable diagnosis of a patient. The optical detection system will form the heart of the qPCR machine.

5.2.1 Origin of Fluorescent Signal

qPCR (q for quantitative) is the process which this machine will perform. As mentioned before, the process involves two main operations: thermocycling, and fluorescence measurement. The thermocycling allows for the separation of the two halves of the DNA molecule, and the reproduction of the DNA molecules for amplification. However, the important process to understand is the operation of the fluorescent detection. The actual detection process will be explained in the following section with the design of the optical system. It is, however, important to understand the source of the fluorescent light. The true origin of this light is the TaqMan probe. When in solution and not bonded to a DNA molecule, the TaqMan probe is inert, and will not emit light. This is because the probe consists of two parts, the reporter, and the quencher. The reporter is what will be the actual source of emitted light, but only when it is free of the quencher and excited by the excitation light source. The quencher serves to disable the reporter from emitting light until it is free. When the DNA strand is extended by the replication process, the strand interferes with the probe. This process, known as cleavage as shown in Figure 5.5, causes the reporter and the quencher to become separated. Thus, the reporter is now free and able to respond to the excitation light source and emits the emission signal which is then detected by the electronics.

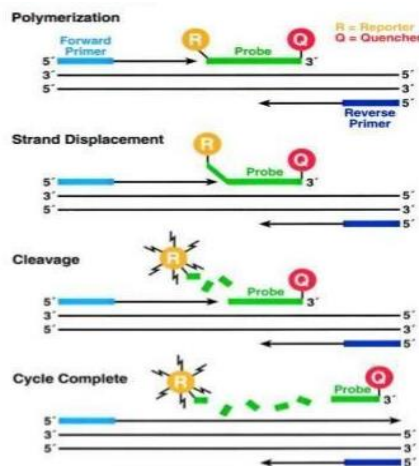

Figure 5.5: Functionality of the TaqMan probe and source of the fluorescence.

5.2.2 Light Source, Detection, and Filters

To design an appropriate optical system, several challenges were faced. The main issue with the design is placing all of the necessary optical components without interfering with the heating element. To face this challenge, the layout shown in Figure 5.6 was designed. In this design, only a small additional feature must be added to the heating element, that is a small hole must be drilled into the side to allow for the entrance of light. The source of light is the LED located towards the bottom of the system and perpendicular to the PCR tube. When a measurement is to be taken, the microcontroller enables the LED and light is emitted. This light travels through the excitation filter which filters out undesired wavelengths. This light is now of a very narrow band of wavelengths and is blue in color. Since the wavelength is quite small, 470 nanometers, the energy carried by it is quite high. As such, when the blue light strikes the fluorescent probes in the sample, the probes are excited and emit light at a lower energy, or longer wavelength, in this case 518 nanometers, a wavelength in the green portion of the spectrum. This green light travels up through the lid of the PCR tube and through the emission filter. The emission filter is another narrow bandpass optical filter centered at 518 nanometers. This filter serves the purpose of making certain that all of the light which reaches the photodiode is green in color. In this way, crosstalk introduced by the blue emission light reaching the photodiode is at the lowest possible value and the reading from the photodiode is a more accurate representation of the amount of target DNA in the sample. The transmission curves of these filters are shown in Figure 5.7. Notice that there is no overlap in the passbands, thus, crosstalk is eliminated.

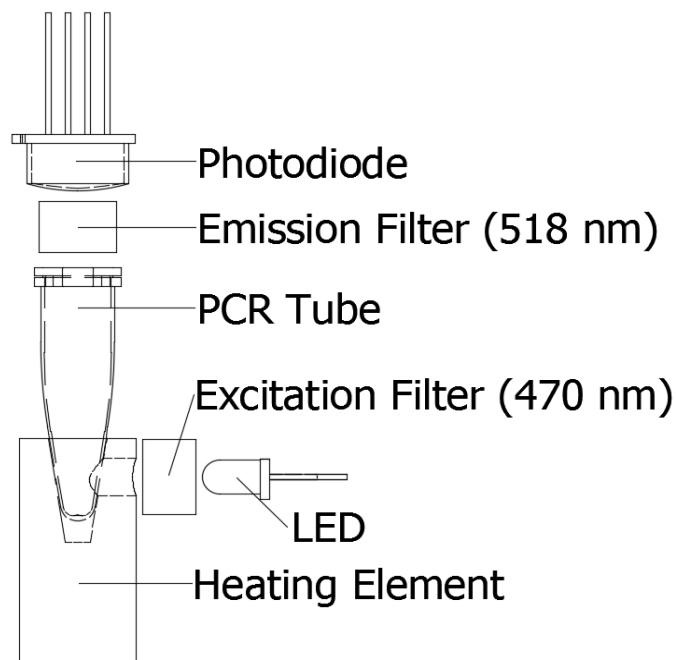

Figure 5.6: Optical components of the qPCR device.

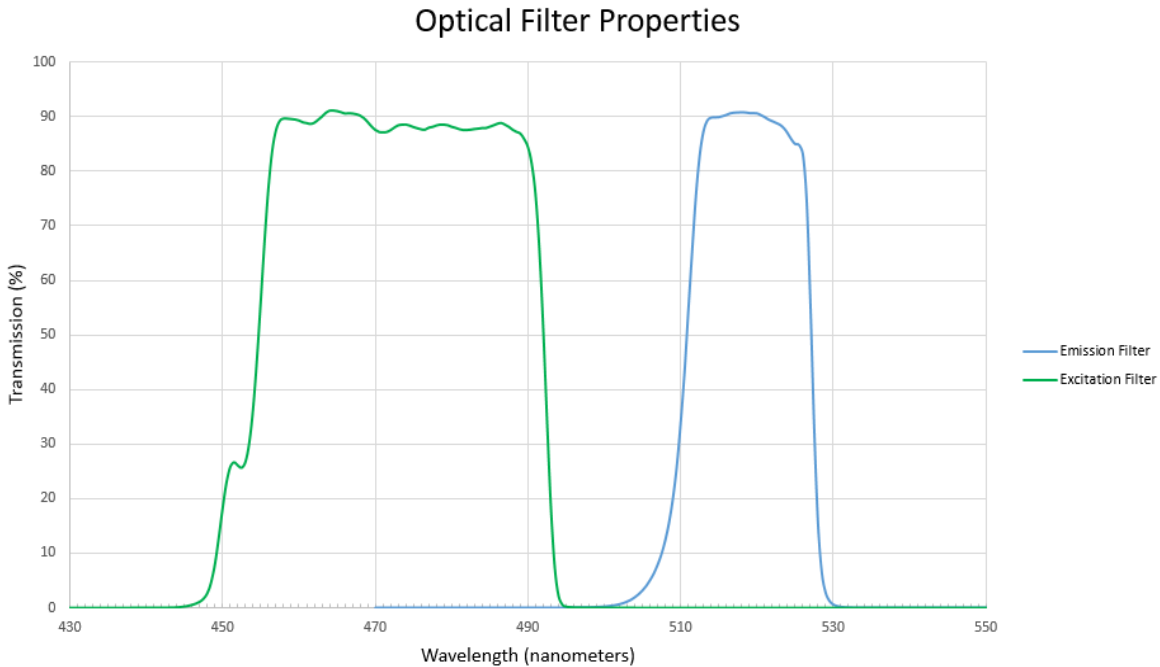

Figure 5.7: Plots showing the passband characteristics of the chosen optical filters. (data provided by Omega Optical) note that there is no overlap of the two bandpass filters.

5.3 Software

Software is the main driving force for most of today's electronic devices. Centralized on a microcontroller, the software included in our device is critical to the function of the finely tuned machine that even extends to the outward extensions such as the android application. Developed through different IDEs and software development kits, the code to run the system is used to manage and operate every aspect of the device. This section explains how the following aspects are designed to aid in the overall management of our system:

- The MCU
- The Embedded Software
- The Android Application
- Online Databases

5.3.1 Main Control

The PCR machine will be a mostly autonomous device that runs based on the settings input by the user either through the mobile application or the manual controls on the device. A simple “start test” command will begin the process based on the settings input and stored in the memory. The on board microcontroller will be responsible for proper execution and oversight of the processes carried out by the PCR machine. It will control the main heating and cooling systems, moving the sample from each desired temperature region, turning on and off the light sources, recording and calculating the data read from the light detector, and managing the display, wireless connections, and local memory.

The device may start one of two ways based on an initial prompt. Upon being turned on the microcontroller will wake up the system and ask the user to connect a compatible device wirelessly. If connected the manual controls on the device will be ignored and the device will take its commands from the mobile application wirelessly. Otherwise, it will take commands from the manual controls on the device. Whichever is used should not have much of an effect on the overall process other than sending the information to the mobile device in case of use of the mobile application or to the local display otherwise.

Once the settings have been input and the user indicated the machine to start, the microcontroller will either decode the information from the mobile device or the local input settings and store it in several variable registers to regulate the process it is about to perform. The microcontroller will devote power to the heating systems to get each to their desired temperature based on the values in those registers and send a signal to the servo to move it to the first heated block needed. The microcontroller will continually read the temperature of the sample through signals from the temperature sensors until it is at the desired temperature that was stored in the register. At that instant, it will send a signal to turn on the light source and detector to test the sample. Once the data is taken, a counter register that has the number of desired cycles will decrement indicating a cycle has been completed. The microcontroller will then send a signal that will move the sample to the next heated block to cool it down, prepping the sample for another heating to split the DNA further. Taking readings from the temperature sensor again the microcontroller will signal the servo to move the sample back the hotter block once the sample has reached the desired cooling temperature that was stored in a register. This process will be repeated until we have reached the desired cycle count indicated by the dedicated counter register becoming equal to zero.

After each data recording, the microcontroller will calculate the concentration of the DNA the user is looking for based on the initial settings given and send the information to be displayed graphically either on the mobile device or on the local display. The display will be continuously updated after each cycle to keep the user updated on the process.

Once the device has reached the desired number of cycles, the display will continue to show the final graph and prompt the user to save if on the local device. The microcontroller will then begin the cooling process inside and prepare to be shut down or restarted based on the user's input from the mobile connected device or locally.

5.3.2 MCU

A Microcontroller (MCU) is a small computer on a single integrated circuit. A microcontroller contains one or more CPUs (processor cores) along with memory and programmable input/output peripherals. Program memory in the form of Ferroelectric RAM, NOR flash or OTP ROM is also often included on chip, as well as a small amount of RAM. Microcontrollers are designed for embedded applications, in contrast to the microprocessors used in personal computers or other general purpose applications consisting of various discrete chips. The microcontroller is typically programmed using an external programmer that uploads the user written code to the IC in the form of machine code. We have chosen to use a microcontroller over other control options due to its versatility, cost, and reliability. Using a microcontroller will allow us to change the code at a moment's notice and allow for easier debugging vs. a purely analog system. The MCU that we have determined to use for the time being will be the Atmega2560. We chose this due to its simple programming environment using the Arduino IDE, vast amounts of community support, low cost, and large amount of I/O pins to ensure we wouldn't run into lack of hardware I/O.

Flash Memory	256 KB of which 8 KB used by bootloader
SRAM	8 KB
EEPROM	4 KB
Clock Speed	16 MHz

Table 5.1: specifications of the Atmel ATMEGA2560 microcontroller.

This MCU requires a minimum input voltage of 4.5 Volts to a maximum of 5.5 Volts and consumes 30 milliamps at idle. The Atmega2560 has 54 digital input/output pins (of which 15 can be used as PWM outputs), 16 analog inputs, 4 UARTs (hardware serial ports) as shown in table 5.1. This microcontroller will be responsible for controlling the user interface, joule heater, temperature sensing, servos, and communication modules.

5.3.3 Embedded Software

The PCR's microcontroller is responsible for controlling and processing data from the different components of the device. The microcontroller, ATmega2560, will be responsible for receiving input and acting accordingly creating a fluid and seamless process for our device to operate. The ATmega2560 has an AVR RISC based CPU that runs extremely efficiently on the C code programming language. Since the ATmega2560 is an Arduino chip and we may use development boards to help code and tune it we will be using the Arduino software IDE to program the microchip. Figure 5.8 shows the main inputs and outputs given to the MCU that will be needed to run the program.

5.3.3.1 Responsibilities

The software will be responsible for taking in inputs from a few sources, interpreting them correctly, and using that data to quickly and accurately send output signals to control the main processes to be checked again. The initial and most important inputs are those from the user interface. Whether they are buttons, a touch screen, or from the android application should not affect the progress but the code will account for inputs from different areas coming from simple button signals, serial interface information from a UART connected to a touch display, or signals from Bluetooth connections. After processing these signals the code should tell the system to start the main process, sending signals to the heating blocks to begin to up the current dedicated to them to begin heating. The program will begin reading signals from the Thermistor to process with PID control discussed in section 3.2.7 to determine the current temperature and adjust output signals to the heating blocks accordingly. Once at the desired point, the program should recognize it is time to flash the led, sending a quick signal to it. Simultaneously, the program should take a quick reading of the photodiode and use the data to calculate the DNA concentration in the sample. Also at about the same point it will begin to signal the servo to move the sample to the next temperature block to repeat the process. As the process is repeated, the MCU will keep track of the cycle count and graph the results slowly, sending the information to be displayed on the user interface either through the UART for the screen or Bluetooth to display on the app. Figure 5.9 shows the software flow of the program.

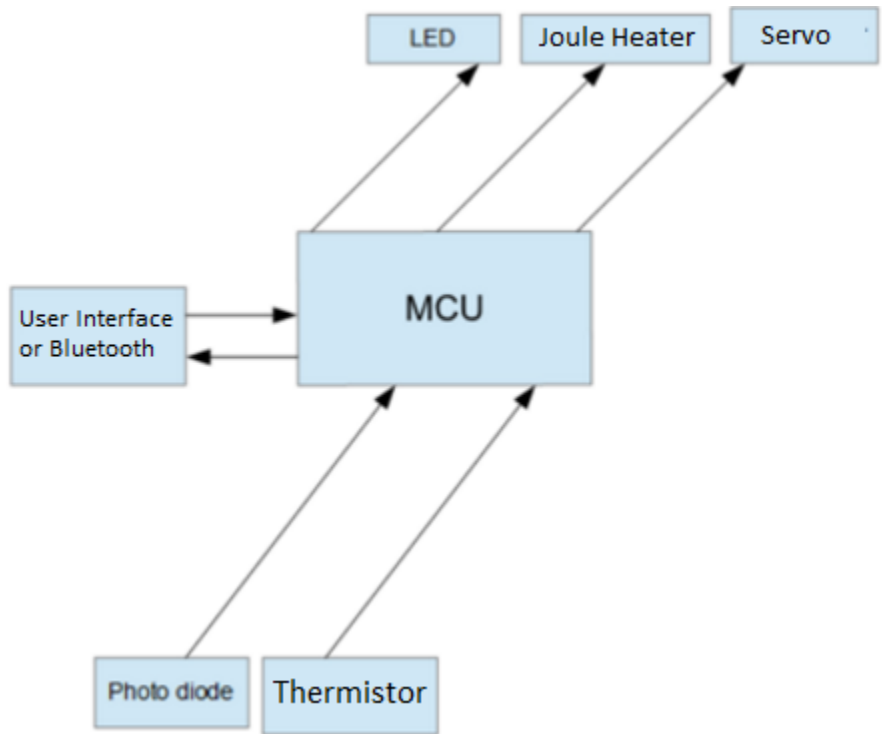

Figure 5.8: Block diagram showing the inputs and outputs the MCU is responsible for.

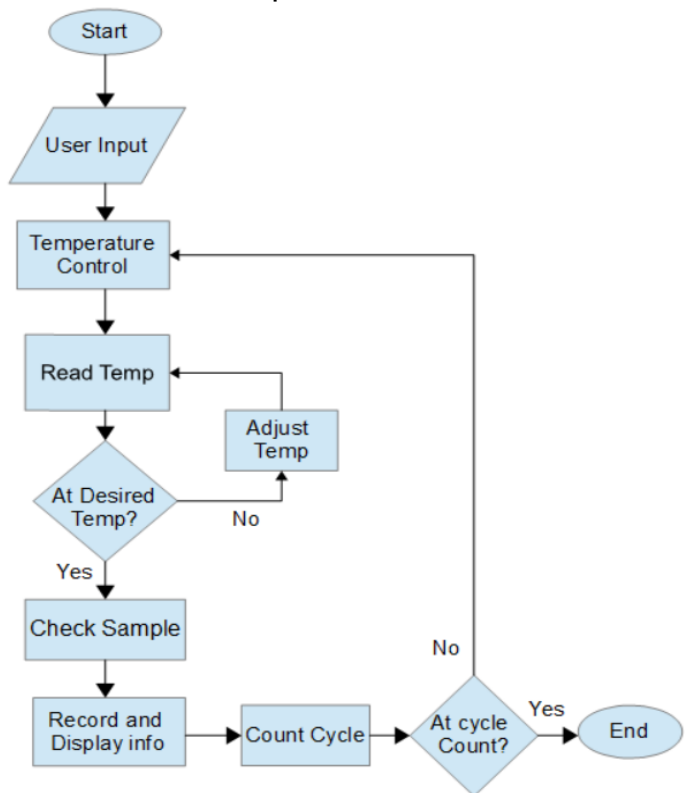

Figure 5.9: This flowchart shows the program flow used to control the PCR machine.

5.3.3.2 Language

To program the ATmega2560 we will use the Arduino Software IDE which uses a language almost identical to the Java programming language. As mentioned before, the AVR chip does work best with C code. Fortunately, the compiler that comes with the Arduino IDE is capable of reducing many higher-level languages to C and is best with Java. Java is definitely a best choice for us to use, keeping the language pretty consistent throughout our device. The application for the android also uses this language because it is a universal language that most computers and systems are familiar with and can easily understand. Java is easy to learn for our members that may not know much and the fact that it is object oriented simplifies things further. There is much support for Java if we have problems and many packages of widely used code we can incorporate in our designs. If need be we can create modular programs to even separate out the different functions and be able to debug, identify, and modify problems areas quickly and easily without affecting the entire program. Because of Java's robustness, ease of use, cross-platform capabilities, and security features, it is the language of choice for our device.

5.3.4 Android Application

The Android application is one of the main focal points of our idea for the portable PCR machine. It is a feature unique to this field whose use will dramatically simplify and greatly expand the use of the PCR machine beyond trained professionals in just a few hospitals to almost anyone. The android platform was chosen for its widespread support and use, its level of freedom in creating an application, and because it is free to do so. The app will be designed to act as a simplified complete control for the PCR machine, allowing the user to adjust settings based on primer used and the specified DNA concentration the user wishes to observe. The app will also be able to start and end the process at the users will. It will also serve as a main display showing the information gathered on neat graphs for quick analysis and will be the main conduit through which information is gathered to be sent to a larger database for further regional analysis.

5.3.4.1 Programming Language

The android application will be written in Java coding language. Android uses a language almost identical to Java and can be easily worked with extensive knowledge in Java. There are also many developing tools available such as MIT app developer which could help in the overall appearance and fluidity of the application which will be used. Android was also chosen for the large amount of support for the coding and availability of previously build classes that could be of

great use for our design. Android's documentation on Java is also easy to understand and a huge online community of developers helps simplify research and development for our application winning Java the language of choice for our device.

5.3.4.2 Software Development Kit and Libraries

The programming IDE Android studio provides the Android software development kit (SDK) and libraries necessary to easily and efficiently develop the application. It is designed to compile and package the application for easy use on any Android device even compatible with emulators to simply test it on demand.

5.3.4.3 Integrated Development Environment

The integrated development environment (IDE) used when working with and developing code for android applications is android studio, a free IDE downloaded from the android developer website powered by IntelliJ IDEA. Android studio is specifically designed to help developers create applications for Android phones with features kept up to date to help make those applications available to Android users through the Google Play online store. The IDE included the SDK and libraries necessary to create a fully functioning android application as well as a virtual emulator to test your designs with. The IDE comes with many helpful features such as code templates based on common features and instant run to push changes to a running application without having to build a new APK (Android Application Package).

5.3.4.4 Application Structure

The application designed to work with the PCR machine will be a linear string of prompts and commands with an option to cancel the present test at any time. The sequence will consist of five main steps:

- Connecting via Bluetooth
- Inputting the settings and user information
- Running the test
- Showing results to analyze
- Submitting results and an option to repeat the process.

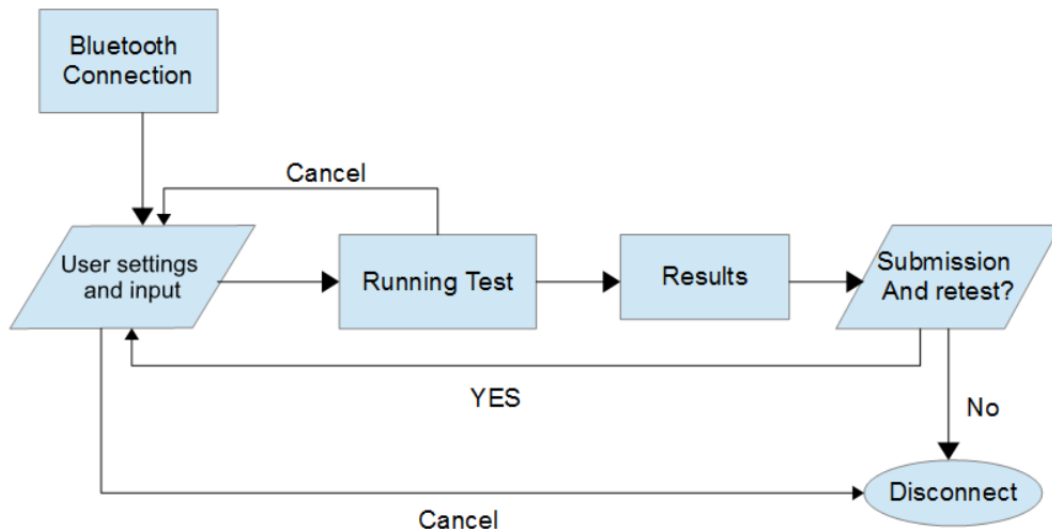

Figure 5.10: This flowchart shows the program flow of the Android application connected via Bluetooth.

The connecting phase will prompt the user to choose the connected device to connect to via Bluetooth or simply display the currently connected device if already done in previous tests or beforehand. Choosing the device in range will connect it to be controlled remotely through the app. Choosing done will test the connection and move on to the next prompts if successful, otherwise showing an error message and suggestion to try again.

Once connected the user will be asked for permission to use their information on the main database for medical studies. If denied the user may continue without putting additional information, otherwise you will be prompted to input basic information such as age, gender, and location. You will then be giving the option to adjust the settings based on what virus you may be looking for in the sample. Some pre-programmed settings will be available for default quick and easy tests for most common PCR uses but you may input your own information such as high and low temperatures, number of cycles, and color of light to use for tests not already programmed or if you need to tweak specific details. An option to save and name your custom settings will also be available. Once all the settings are in the user may press start. If there is something important left blank the user will be alerted and asked to input the settings information before the test can begin.

While the test is running, a graph will be visible for real time analysis. The user can see the results of each cycle graphed as it occurs and see the current progress of the test. As mentioned, a button to cancel the test will always be available, here with an extra “Are you sure?” question incase cancel is accidentally pressed

during the test avoiding an accidental stop halfway through. This phase is mostly just a visual as the test will continue to go until done with only the option to cancel if needed. Once it has finished running you will be taken to the results.

The results page will be the final results displayed as well as minute other details about the test. The user will be able scroll through the data and find points of interest, email the report to themselves or their patient, and can name and save the data to the local memory on the device. When finished, press done.

Once done the user will be prompted to verify the data to be sent to the database to add to the medical database for future studies. There will also be an option to retest for a second opinion or be done and shut the device off.

5.3.5 Online Databases

A major focus for the portable PCR machine is to be able to gather information anywhere with ease and send this data to a single large database for future studies. The database will be used to study trends in location, age, gender, and even over the course of certain time periods (Seasons, weeks, months, years, etc.). Analysts and doctors can use the information to track the progress of the diseases and take action accordingly. This could reveal hidden seasonal activity, trends in age groups, show where outbreaks may be concentrated, or even reveal how different cultural groups and areas may suffer differently from exposure to the diseases.

This aspect of the project may take some time to really develop into a working system for the future product so for our project we will build a simple proof of concept that can be built upon later if need be. For now we just need a simple online database or cloud storage program to hold the data as we see fit from the android app. There are a few good options available out there such as a TinyWebDB, FirebaseDB, and Google's fusion tables. All of these are not necessarily for long term use and are considered more experimental. We considered these because they are free, easy to use, and can support our need for a proof of concept.

5.3.5.1 TinyWebDB

TinyWebDB is not a specific service but stands for a tiny web database that can be accessed from the web to store and retrieve data for programs on an online database. This was brought to our attention because the MIT app inventor we are using to aid in the development of the app has good support of it. A tiny web database would be the most trusted service for us to use but its setup is a bit tricky. Another downside to its use is that it has a relatively small amount of space

which shouldn't be too bad for our experiments but data would be quickly overwritten. Google does have one that could be useful called google app engine but this would require coding an entire new service and potential software to support just what we want. It is a great opportunity for future development but just not exactly what we need at the moment for it is only a trial product only truly useful with purchase, potentially for further development if need be.

5.3.5.2 FirebaseDB

FirebaseDB is another web database specifically designed to work with apps. Most of its features are completely free and it comes with many APIs all covered in one software development kit. It allows for great development with lots of support, private databases, and access to data for any users desired. This would also make a great future platform for future developments of our app to go with the PCR machine but also needs much attention and design. It has many useful functions already available for use but we simply don't need anything this fancy just yet. It is more for actual business and professional use of the applications it powers. Used more for online chats or personal databases to store user information FirebaseDB is more than we need honestly but could definitely be a huge help for future development allowing for the kind of analyzing we need for professionals to make quick sense of the database.

5.3.5.3 Fusion Tables

Google's Fusion tables is a simple online table much like something from excel. This is perfect for what we need because it is much like an online google doc that can be shared with specific participants but that anyone using the app can add to. It is a simple table with fixed columns with the information we need such as gender, age, date, disease tested for, and location as seen in figure 5.11 with random examples of what would be filled in. More columns such as DNA concentration and other result statistics will be added in as well later on.

Gender	Age	Date	Disease	Location
Male	23	2017-04-11	HIV	17eme Ave, Bujumburaa, Burundi
Female	33	2017-04-12	AIDS	West Kalimantan, Indonesia
Female	23	2017-04-12	HIV	3.190 N, 101.6869 E
Male	33	2017-04-11	AIDS	31.9505 S, 115.8605 E

Figure 5.11: An example of Fusion Table's data logging in a table with examples

Each column will be filled in with simple information directly from the android application. Gender will be a choice between the options. Age will be in number format simply inputting a number. If a valid number isn't put it will either ask the patient to try again or simply remain blank. The date will be given automatically from the phone's internal clock. The disease type will either be a choice or a custom input, almost anything could be inserted there. The location can be an address or geolocation based on coordinates given from the mobile phones positioning system or the GPS on the actual machine. All columns are completely optional but for best analysis all of them should be filled out correctly.

Fusion tables will be our first choice as well for the convenient features available to the ones with access to the actual table. It allows for quick overviews of positions on google maps as well as simple table tools to quickly view, compare, and analyze data that we have collected. An example of mapped locations including the one for the addresses and coordinates seen above in figure 5.11 can be seen in figure 5.12 where the coordinates input are for Perth, Australia and Kuala Lumpur, Malaysia respectively and are shown correctly in the map. Examples of a graph can also be seen in figure 5.13 along with some of the filter options based on the data provided. With this we can quickly visualize based on location, gender, date, etc.



Figure 5.12: Fusion Table's location mapping system using google maps with the random examples used above.

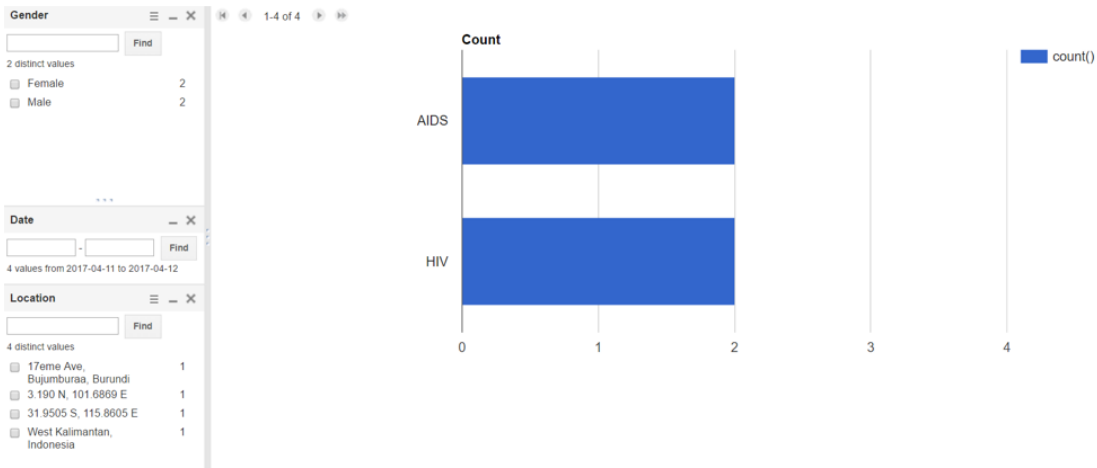

Figure 5.13: A snapshot of a bar graph view of Google's Fusion Tables with potential filter options seen on the left.

5.6 Power Systems

The power systems in this device will power various systems and subsystems within the PCR machine, assuring their continued and efficient operation.

5.6.1 Switch Mode Power Supply

To supply power to the board and various components a Switch Mode Power Supply (SMPS) will be used in the Buck-Boost topology. A switched-mode power supply regulates either output voltage or current by switching ideal storage elements, like inductors and capacitors, into and out of different electrical configurations. Ideal switching elements (e.g., transistors operated outside of their active mode) have no resistance when "closed" and carry no current when "open", and so the converters can theoretically operate with 100% efficiency (i.e., all input power is delivered to the load; no power is wasted as dissipated heat) (Figure 5.14).

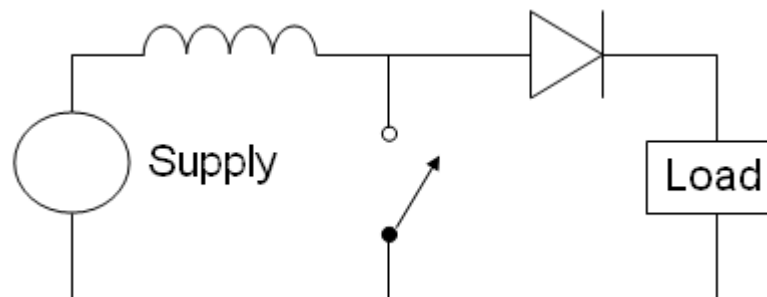
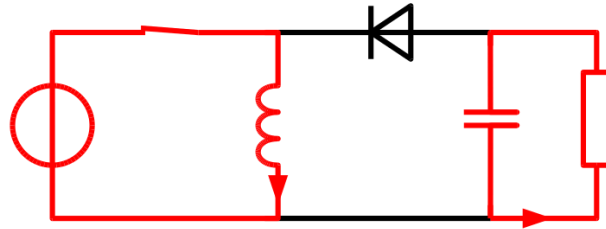

Figure 5.14: Schematic of basic SMPS.

The two operating states of a buck–boost converter are shown below in Figure 5.15. When the switch is turned on, the input voltage source supplies current to the inductor, and the capacitor supplies current to the resistor (output load). When the switch is opened, the inductor supplies current to the load via the diode D.

On-State



Off-State

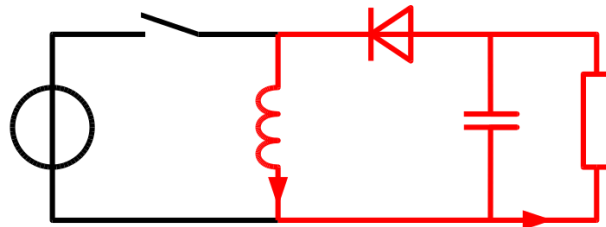

Figure 5.15: The two states of the SMPS.

We chose this style of SMPS because it allows to achieve our desired output voltage (5 Volts) at any input voltage from the range of 2 Volts to 16 Volts. This is exceptional since our batteries can range from a fully charged input voltage of 4.2 Volts to a full discharge voltage of 2.5 Volts. Also this design will allow for the circuit to be highly efficient achieving an efficiency of 88% or greater at the lowest input voltage (2.5 Volts). The advantages of this circuit over a linear power supply is its efficiency, where typically you would see an efficiency of less than 50% we will be seeing 88% or greater depending on current draw. You would also see a very high power dissipation in the circuit, wasted as heat. From our calculations using the formula:

$$Power = [V_{in} - V_{out}] * I$$

This formula gives us a power dissipation of 3.3 Watts, which is entirely too much wasted energy and would also result in the board heating up in turn decreasing the efficiency of other IC's on the board as well. This was the deciding factor against using any linear regulators.

SMPS regulators also come in many shapes and sizes most of which are extremely small which will lend a hand to keeping our size down enhancing our portability and keeping weight down as well. The external components required

are also minimal which lends to keeping the cost down.

5.6.1.1 Decision

For our SMPS we will be using the Texas Instruments TPS63070, which can take any input voltage from 2 Volts to 16 Volts and output 5 Volts at 2 Amps. The reason that this was selected is it's relatively low cost (2.83\$ in single quantity), readily available at many electronics distributors such as Mouser or Digikey, and low external part count required that being only nine external low cost passive components. The application schematic from the data sheet is shown below in Figure 5.16 and parts and characteristics considered between a few different potential parts are shown in Table 5.2.

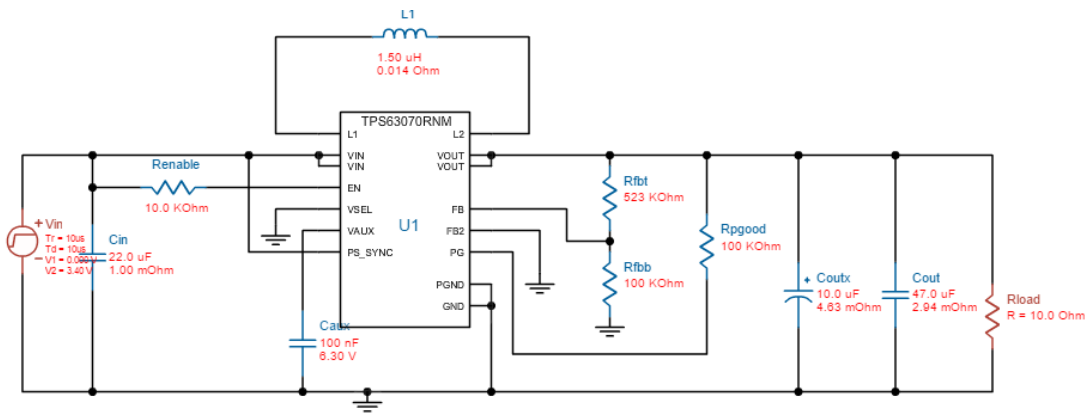

Figure 5.16: SMPS schematic using the Texas Instruments TPS63070.

SMPS Parts Selection

	TPS63070	MCP16301T-I/CHY	ISL95870HRUZ-T
Output Voltage:	2.5 V to 9 V	4.0V to 30V	500 mV to 5 V
Output Current:	2 A	600 mA	30 A
Input Voltage:	2 V to 16 V	2 V to 15 V	3.3 V to 25 V
Switching Frequency:	2.4 MHz	500 kHz	300 kHz to 1 MHz
Topology:	Buck, Boost	Current Mode PWM	Current Mode PWM
Package / Case:	VQFN-HR-15	SOT-23-6	UTQFN-16

Table 5.2: SMPS parts selection

5.6.2 Charging

To charge our batteries we will need an Integrated Circuit (IC) which will handle the entirety of the current and voltage control into the battery cells as building our own will be too time consuming. These devices operate as Switch Mode Power Supplies (SMPS) pumping current into the battery until it begins to consume little to no current and then operates in a constant voltage operation to keep the battery topped off while on the charger. The charger we have chosen, the bq25896 is a highly-integrated 3-A switch-mode battery charge management and system power path management device for single cell Li-Ion.. The devices support high input voltage fast charging. The low impedance power path optimizes switch-mode operation efficiency, reduces battery charging time and extends battery life during discharging phase. The I2C Serial interface with charging and system settings makes the device a truly flexible solution. This charger has large array of features including I2C communication, USB detection, and even an USB OTG function which itself is a SMPS user output. Its specifications are shown below Table 5.3.

	BQ25896
# Series Cells	1
Function	Charger
Cell Chemistry	Li-Ion/Li-Polymer
Battery Charge Voltage (Min) (V)	3.84
Battery Charge Voltage (Max) (V)	4.6
Special Features	Integrated FET JEITA BAT Temp Monitoring (Thermistor Pin) OTG (On The Go Boost) Power Path Temp Monitoring (Thermistor Pin) Thermal Regulation
Charge Current (Max) (A)	3
Control Interface	I2C Standalone (RC-Settable)
USB Feature	USB OTG USB PSEL
Rating	Catalog
Operating Temperature Range (C)	-40 to 85
Pin/Package	24WQFN
Operating Vin (Min) (V)	3.9
Operating Vin (Max) (V)	14
Absolute Vin (safety rating) (Max) (V)	22

Table 5.3: specifications of the BQ25896.

This device is able to be implemented with relative ease, shown Figure 5.17 below you can see that only 20 low cost, small sized components are required which can be acquired quite cheaply.

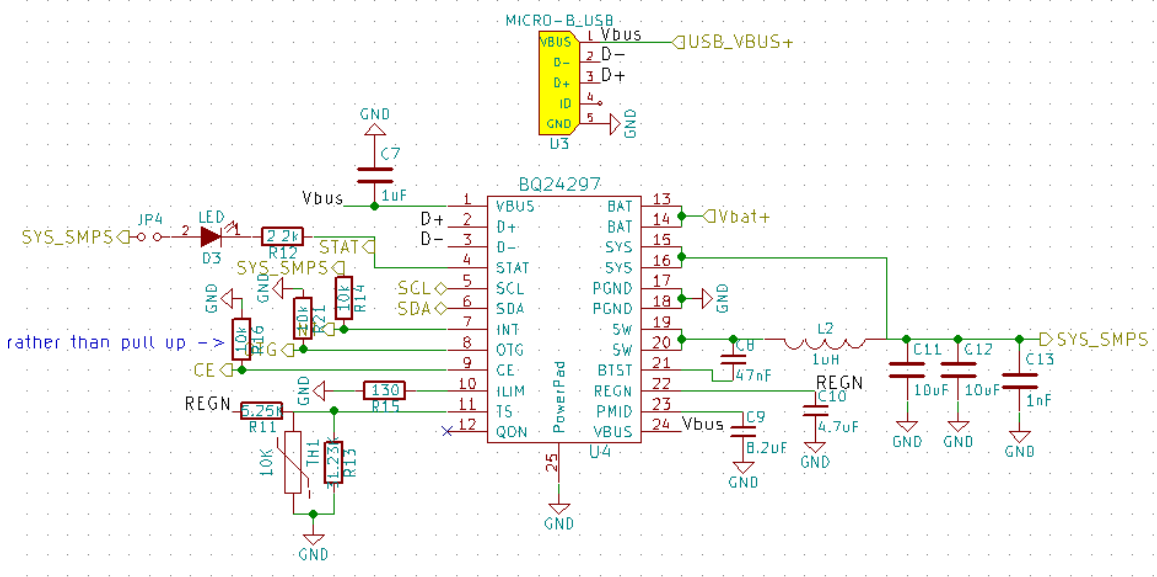

w6

Figure 5.17: Schematic of a low parts count charger

5.7 User Interface

An important piece of our design is the user interface. The interface is what truly connects the device with the user and all of its many operations. For this reason, the user interface should allow the user to be able to perform the tasks they are trying to accomplish with ease. The ease of use will allow the user to operate the true potential of the device, meaning they should be able to use all of the features that the device has to offer. Another consideration we have for the interface is safety. We are dealing with potentially harmful substances and is recommended that all users take every precaution in dealing with these substances. For this reason, our device interface should be operable when the user has gloves on their hands.

5.7.1 User Selection and Navigation

The user selection will be the part of the device that the user will interact with to manually select and control the device. We will begin assessing multiple options and see what is the best for our requirements.

5.7.1.1 Push Buttons

Push Buttons offer a wide variety of options when it comes to layout. The portable PCR machine should be as small as possible. Buttons, however many necessary, can be oriented in the optimal location for minimizing the addition of space. The quantity of buttons required for convenient operations will be determined during the process of coding our processor. Acquiring or removing buttons is a simple task. Buttons are simple to code and also can be operated by someone with gloves on their hands. Push Buttons can be active high or active low. All though Buttons do face an issue with bouncing. Bouncing is a scenario that occurs throughout its activity. Typically when a button is pressed the button signal will continuously jump back and forth between 1 and 0 (pressed and not pressed) every millisecond or less repeatedly for several milliseconds before it settles. Even after the signal settles in the button's proper orientation they are still spurious jumps that occur. These issues if not taken into account could cause error when the user selects an option and the program recognizes a different signal than what was selected. There are many ways around the bouncing such as to have a Schmitt trigger button with a flip-flop or to program a debouncing code. Figure 5.18 displays the bouncing signal. Figure 5.19 displays one of few circuitries that de-bounces the signal.

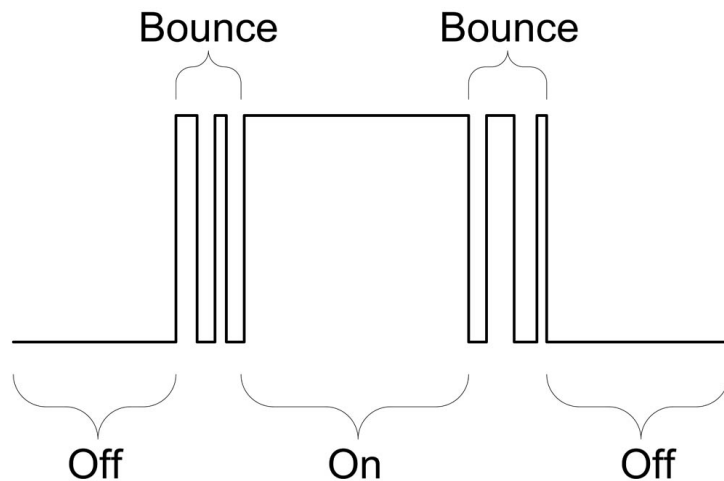

Figure 5.18: waveforms caused by switch bouncing.

As explained above bouncing occurs when the push button is pressed and the signal continuously moves to and from 1 and 0 (On and Off)

Figure 5.19 demonstrates circuitry that de-bounces the signal and makes the signal accurate to user's desired input. The circuitry uses a switch that alternates between two nodes, A and B, both of which experience bouncing. After both node A and B are connected to a JK Flip Flop the resulting output is a smooth

debounced signal.

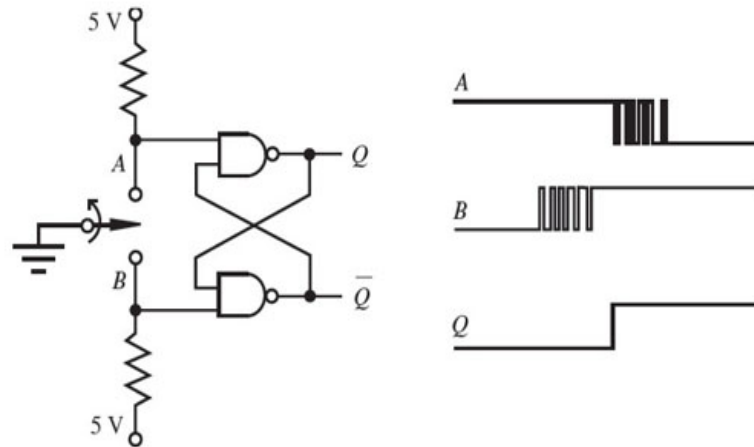

Figure 5.19: schematic and waveforms of a debouncing circuit.

5.8 Mechanical System Design

For the process of thermocycling, it is necessary to move either the PCR tube or the heating and cooling elements with respect to each other to control the sample's temperature. We have decided to use the former method where the PCR tube will remain stationary and the heating and cooling elements will move with respect to the PCR tube. This decision was made so that the optical system can remain stationary and therefore, less prone to errors. The system we have designed consists of two servomotors that move the mechanical components. One of the servos controls the angular position of an arm that will hold the heating and cooling elements, allowing for the selection of either heating, or cooling. The other servo controls the vertical position of the arm, this allows for the heating and cooling elements to be raised to the position of the PCR tube. Combining these two actions allows for the temperature of the PCR tube to be controlled by selectively placing the tube in either the heating or cooling mode of operation. These two operations are shown in figure 5.20. For the user to insert the PCR tube in order to perform an experiment, the top part of the device opens up to allow access to the internals. This is shown in figure 5.21, which also shows the location of the custom PCB which holds all of the electronic control components.

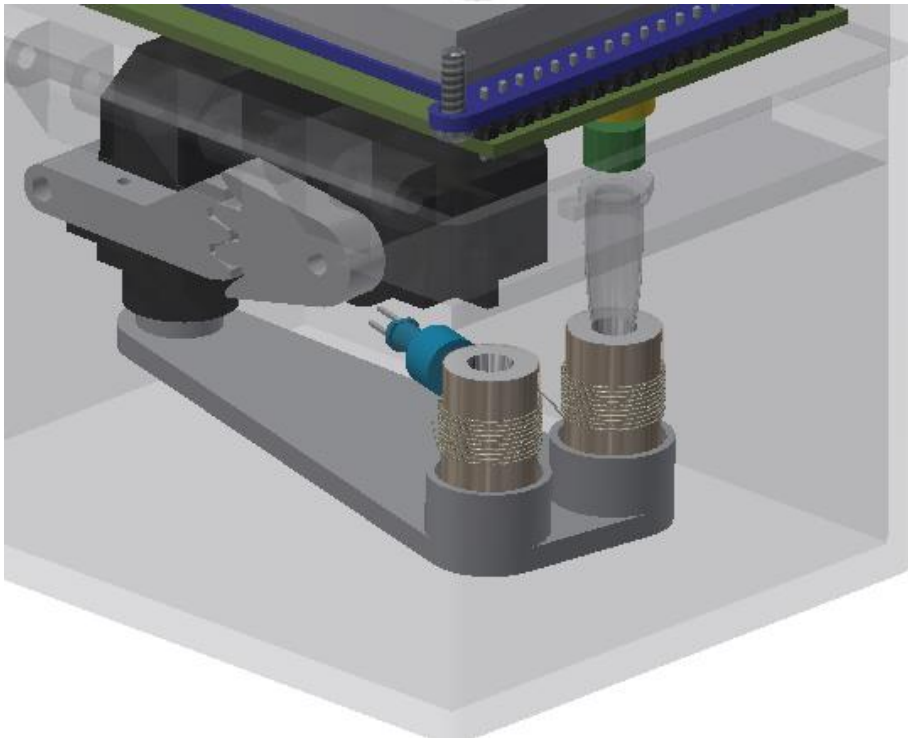
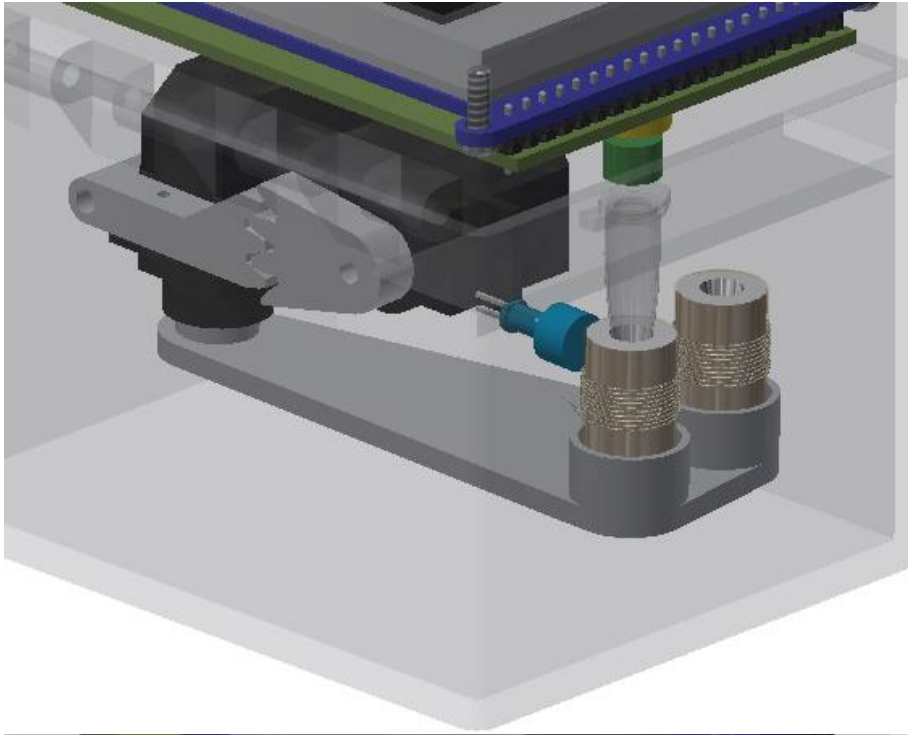

Figure 5.20: The two temperature control modes of the device, top: cooling mode, bottom: heating mode.

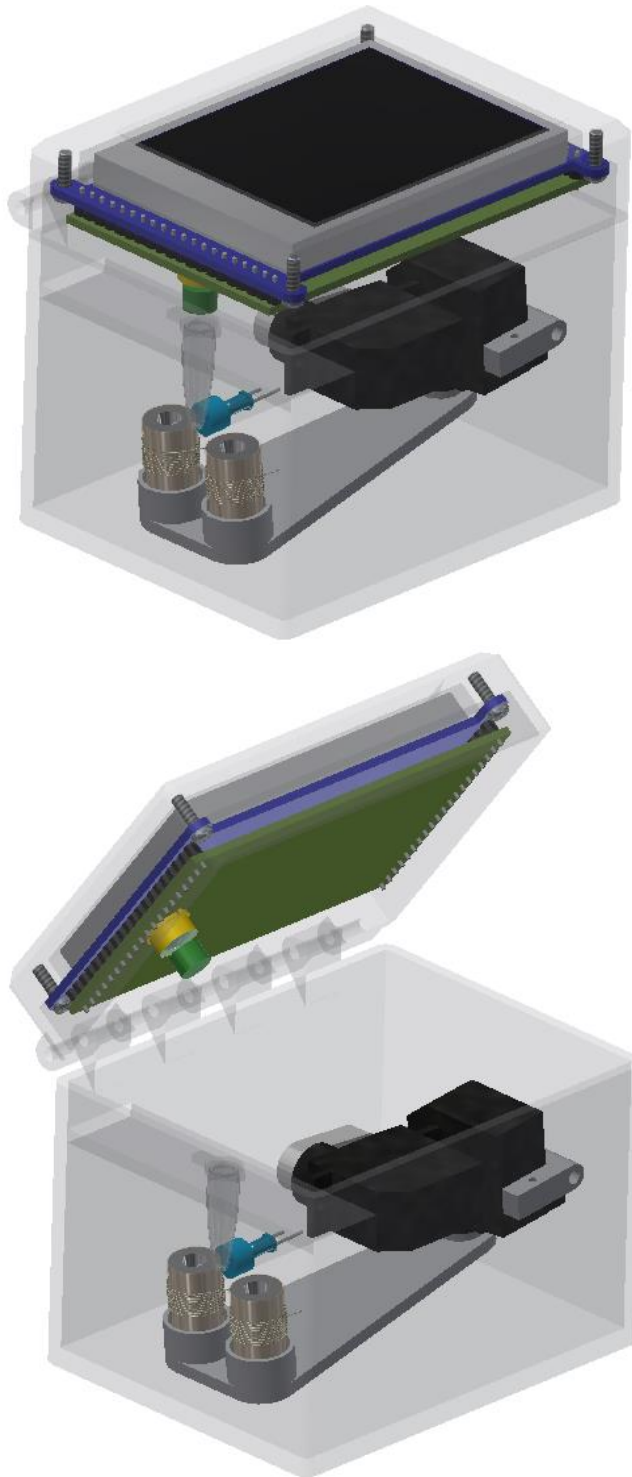

Figure 5.21: Demonstration of the opening of the device. Top: the device in its closed state, bottom: the device with its lid open, allowing insertion of the PCR tube. The green board is the main PCB.

5.8.1 Servo Motors

In order to provide movement to the various mechanical parts of the system, some form of electric motor is required. In this case the use of servo motors was a clear choice as they provide a number of critical benefits when compared to other types of motor. The most important feature of a servo motor is the ability to position the output shaft. This operation is based on a closed-loop feedback system that is completely contained within the servo itself. This system usually consists of some form of optical rotary encoder wheel which allows a controller to determine the precise position of the output shaft and allows for adjustments in angular position to be made. This type of encoder is shown in (the figure). Since this precise positioning system is integrated inside of the servo motor itself, this eliminated the need for a complex positioning system to be designed as an external system. Another benefit to the servo motor is the extremely compact form factor in which they are available, this aids in making the overall design for the PCR machine as compact as possible. These servo motors are controlled by the main microcontroller using PWM.

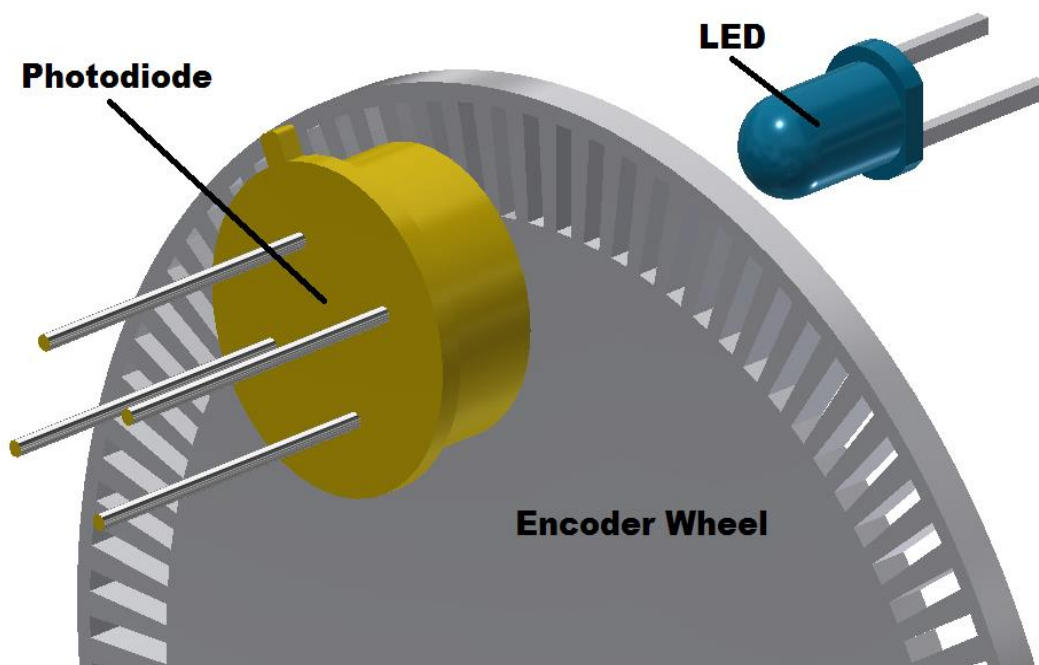

Figure 5.22: Detail of the rotary encoder used in a servo motor, light from the LED is passed through slots on the encoder wheel and is read by the photodiode. The pulses of light seen by the photodiode allow for the controller to determine the position of the encoder wheel.

5.9 Component Interface Design

Some parts of our design will need a few more connections to the microcontroller rather than just a simple wiring to the PCB board connecting them. These will need to be highly considered when designing our own PCB board and tested to make sure they work well.

5.9.1 Bluetooth Interface Design

To communicate with outside devices (send and receive information) we have chosen to use a readily available Bluetooth module that is pre-built onto a breakout board, the HC-05. This module greatly simplifies communication with the outside world. The module acts as a wireless serial port between it and any other device, making it capable of sending and receiving data at speeds of up to 460800 baud. It's also capable of transmitting at a power of +4dBm with a -80dBm sensitivity giving it a range of ~10 meters. This module is commonly referred to as the HC-05, but really what runs it is an IC, the "BC417143B BlueCore 4-External". Ideally we would implement the chip itself, but since it's a BGA package, it's far from ideal soldering in a home or school lab. In production though, this IC itself would be used which would reduce the cost of needing an external breakout board and associated components. The schematic for this HC-05 to Atmega2560 interface is shown below in figure 5.23. The Pinout of the HC-05 module can be found below as well as how it interfaces to the Atmega25660 (Table 5.4).

Pin:	Description:	Atmega2560 Pin:
KEY	If brought high before powered on, enables AT command mode	~
VCC	Will accept anywhere from 3.3 to 5 Volts input	~
GND	Ground connection for the circuit	GND
TXD	Transmit Serial Data line	RX1 (UART)
RXD	Receive Serial Data line	TX1 (UART)
STATE	Outputs a high signal if a device is connected	Digital pin 26

Table 5.4: HC-05 pinouts

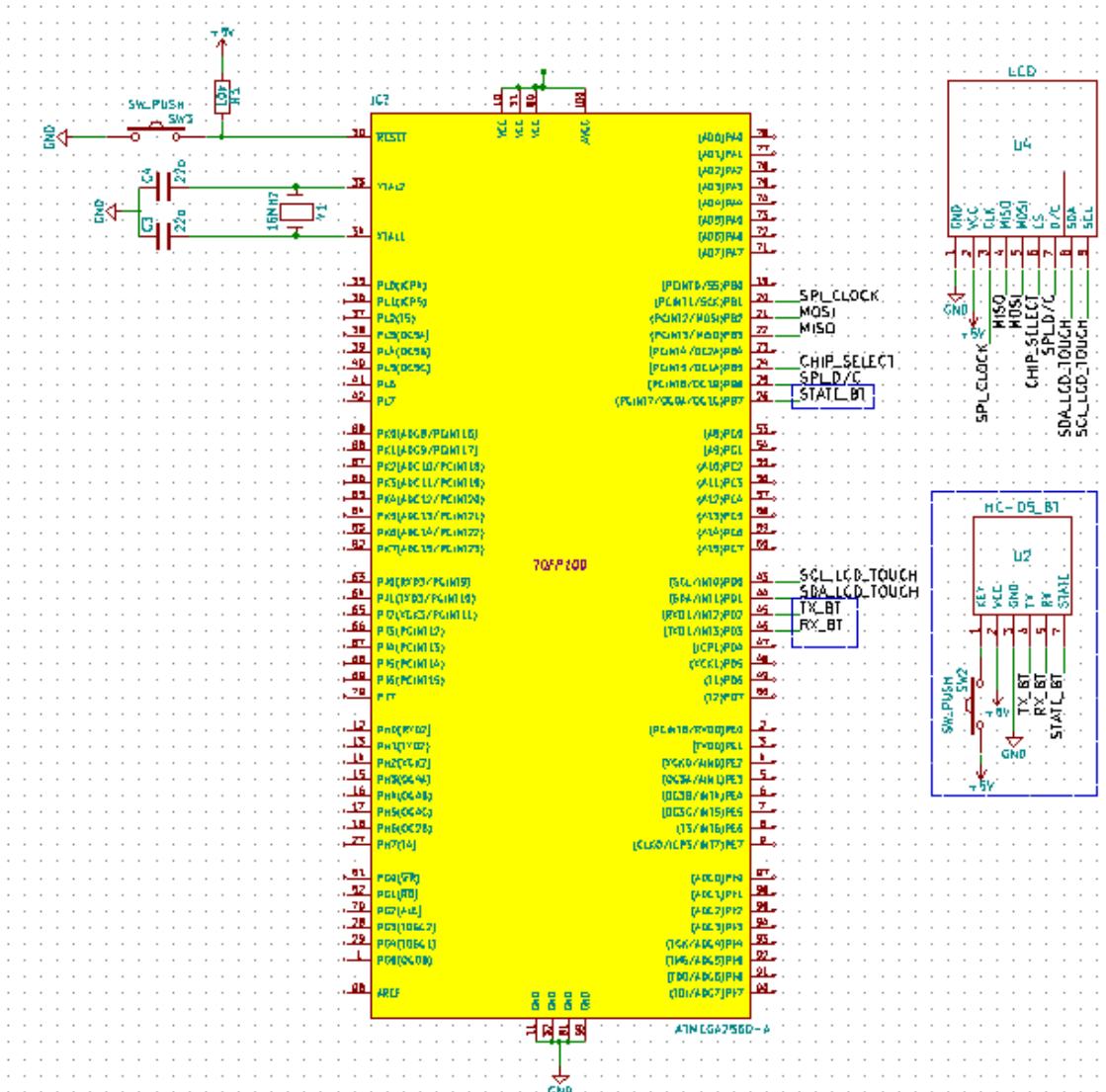

Figure 5.23: Interface Schematic

5.9.2 Thin Film Transistor Liquid Crystal Display Interface Design

To interface with the user we will be using a Thin Film Transistor (TFT) Liquid Crystal Display (LCD). This TFT LCD is 2.8in across and incorporates a resistive touch screen overlay as well as a micro SD card reader. These all communicate using Serial Peripheral Interface (SPI). We chose this because of its overall small size while yet still maximizing on a larger user interface, as well as including the touchscreen which will eliminate the need for any external button hardware. We plan on displaying all user data through this interface also will make this the single point of user interaction other than the power switch to actually turn everything on.

This further simplifies our design process and ensures that there is less time spent designing and debugging the machine as it's built. The TFT LCD's pinout is as listed (Table 5.5). The schematic for this TFT LCD to Atmega2560 interface is shown below in figure 5.24.

Pin:	Description:	Atmega2560 Interface Pin:
Vin+	This will take an input voltage of anywhere from 3-5 Volts	~
GND	Ground connection of circuit	GND
MISO	(Master In Slave Out) This is used for SPI communication	MISO, pin 22
MOSI	(Master Out Slave In) This is also used for SPI communication	MOSI, pin 21
CS	This pin in the Chip Select pin which is pulled either high or low to "Select" the device for communication	CS, pin 24
D/C	This pin determines if the SPI connection is an incoming data or command format by being pulled high or low	D/C, pin 25

Table 5.5: pinouts for the display module and their connections to the ATMEga2560.

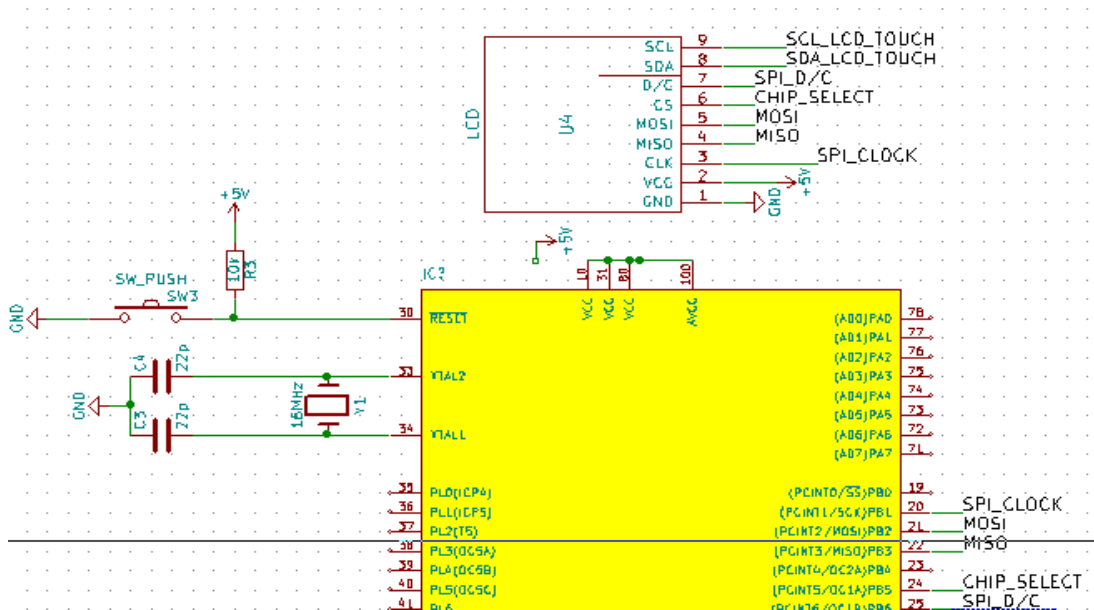

Figure 5.24: Schematic interface

5.10 Breadboard Testing

In the design of any project consisting of electronic components, a phase of breadboard based testing is a requirement to ensure that the chosen components will work together before the design and commitment of a PCB submission. In this section, we demonstrate the tests performed on the various electronic components chosen by the group that will form the basis of the electronic systems of the device. One important fact to note is that much of this testing is performed using development boards which are a cost effective means of testing a component before designing a PCB, as such, the components tested using a development board will not be attached to development boards in the final product. Instead, these devices will be soldered directly to the custom PCB that will be designed. This also has an additional advantage of allowing the final product to be much more compact, due to the fact that wasted space taken up by the development boards will be eliminated on a well-designed custom PCB.

5.10.1 Touchscreen Display Testing

To ensure that the touchscreen that we have chosen for this design is functional and is able to be controlled in an effective fashion a test was performed. For the test, a simple program which allows for the user to draw on the screen and responds by coloring in the pixels of the display under the user's stylus. This test demonstrated the ability of several important components in our design. The first is the functionality of the chosen display and its ability to be controlled by software, the second demonstrates the operation of the touch panel that will be used for all primary user input to the PCR machine without dependency on the mobile application, and the final is the ability for the Atmel microcontroller to interface with both the display and the touch screen. A photo of this test is shown in figure 5.25.

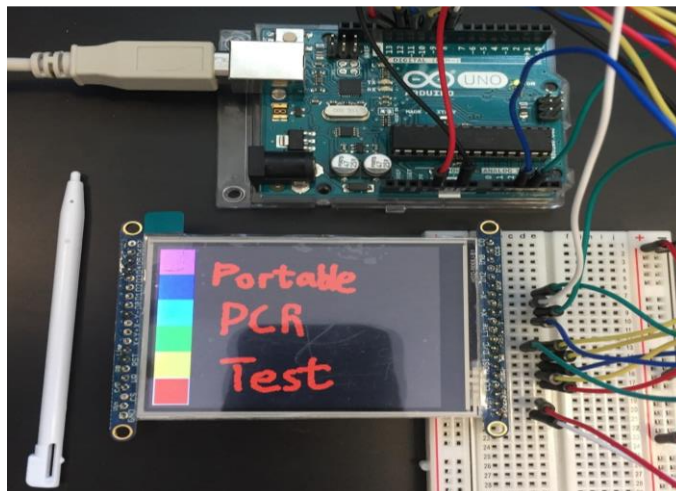

Figure 5.25: Breadboard test of the LCD, touchscreen, and Microcontroller.

5.10.2 GPS Module Testing

One of the elements of the project is the ability for our device to record the location of the detection of a disease. Since we have decided to complete this task using GPS, a test of the chosen GPS module was necessary. This module communicates via a serial connection. Once the data is read by the UART on the microcontroller, it is then converted to latitude and longitude. These values were then printed to the display in order to demonstrate the device's functionality as shown in figure 7.4. Notice that the coordinates, 28.58 degrees north and 81.19 degrees west are located just to the east of the UCF main campus, precisely in the location that the test was being performed. This test confirms that the module will work with out Atmel microcontroller and will provide suitable location accuracy for the purposes of our device.

5.10.3 Bluetooth Module Testing

An additional element required for this project is the means of communication with the mobile phone application. To achieve this task, we have chosen to use bluetooth, as it is a protocol found on many mobile devices. To test the module we have chosen, the device is connected on the breadboard to the microcontroller using another UART. This device appears to the microcontroller as a serial port and allows for both the transmission and reception of data bytes. This communications will be used in the final product to send data to and from the mobile application. In this setup, the module was tested by forming a connection with another bluetooth device, in this case a laptop, and the result of the pairing was displayed on both the laptop and the display connected to the microcontroller as shown in figure 5.26 and figure 5.27. This forms a communication channel that can be used to control the PCR device once the proper software is written.

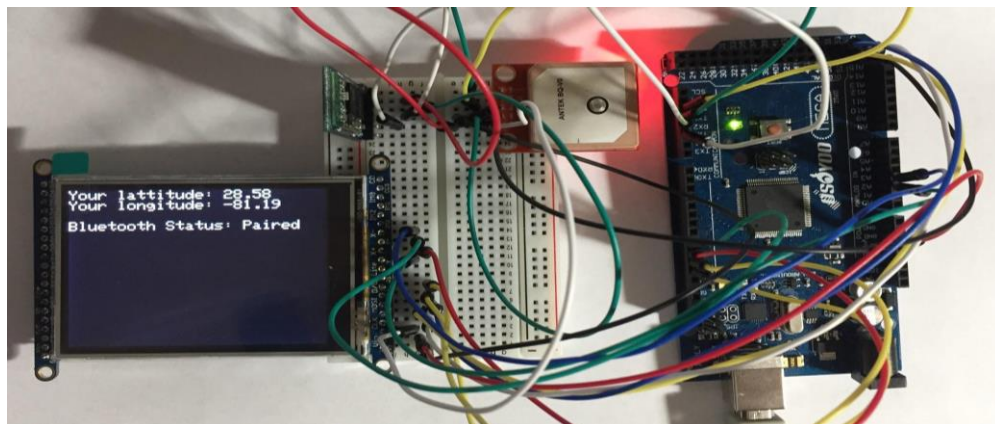

Figure 5.26: Breadboard testing of several major components simultaneously.

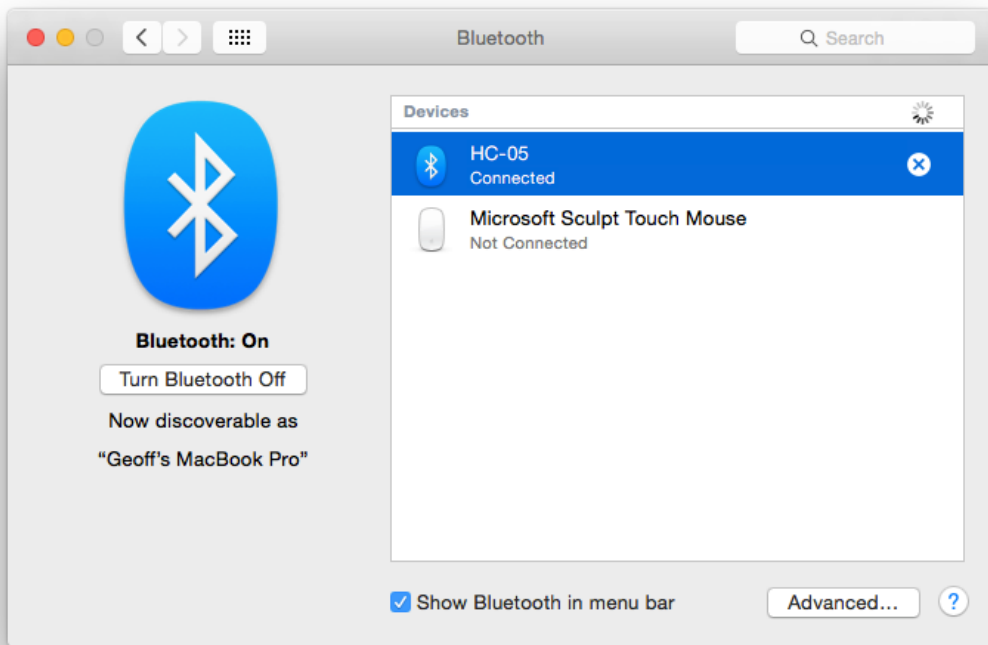

Figure 5.27: Screenshot from the laptop confirming the successful pairing with the bluetooth module connected to the microcontroller on the breadboard.

6 Project Prototype Construction

Several of the components require a construction process as they are not available off-the-shelf. This chapter will explain in detail the techniques used to construct them.

6.1 Construction of Aluminum Heating Block

For accurate temperature control of the sample, the shape of the heating element is of the highest importance. Unfortunately the shape of the PCR tube makes the construction difficult. As shown in Figure 6.1a, the tube has a taper which is designed for a solid and strong fit as the tube is inserted into a heater. In order to machine this shape, several steps will be performed, firstly a standard cylindrical hole is bored slightly undersize to remove the bulk of the aluminum so that the reamer will not have to remove a large amount of material. Secondly, a custom-made shaping tool is used to expand the hole into the correct conical shape. This shaping tool is shown in Figure 6.1b. This tool is constructed from steel so that it is harder than the aluminum that will be used for the heating element. The outer shape of the tool is made by rotating a steel rod against a grinding stone at an angle of 8.75 degrees, this results in an included angle of 17.5 degrees which is the same as the bottom of the PCR tube. Then, the tool is held against the grinding stone and move radially into the stone, this creates a flat side of the tool which will be used as the cutting edge when bored into the aluminum heating element.

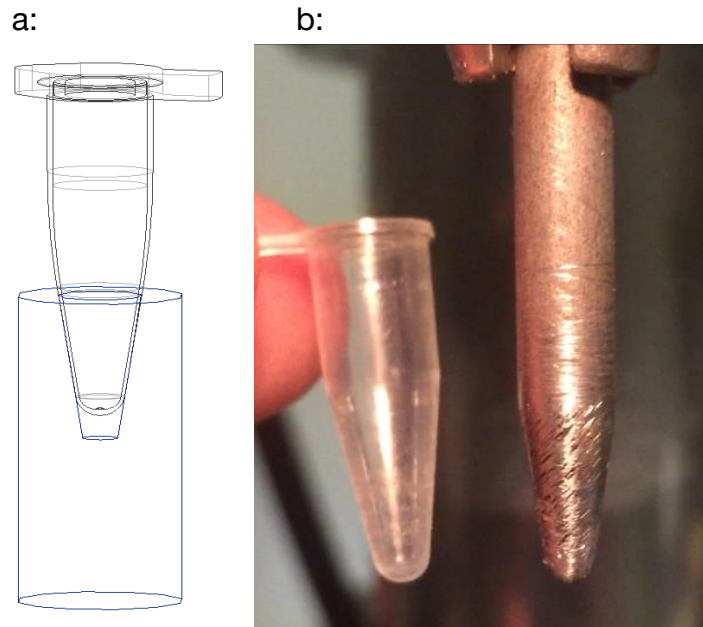

Figure 6.1: a: Detail of the heating element and PCR tube contact. b: Shaping tool used to bore conical hole in the heating element.

6.2 3D Printing of Parts

Most of the non electronic parts of the device are made by 3D printing. This method of construction involves heating plastic to its melting point and depositing it by use of a CNC extruder. An example of this process is shown in figure 6.2

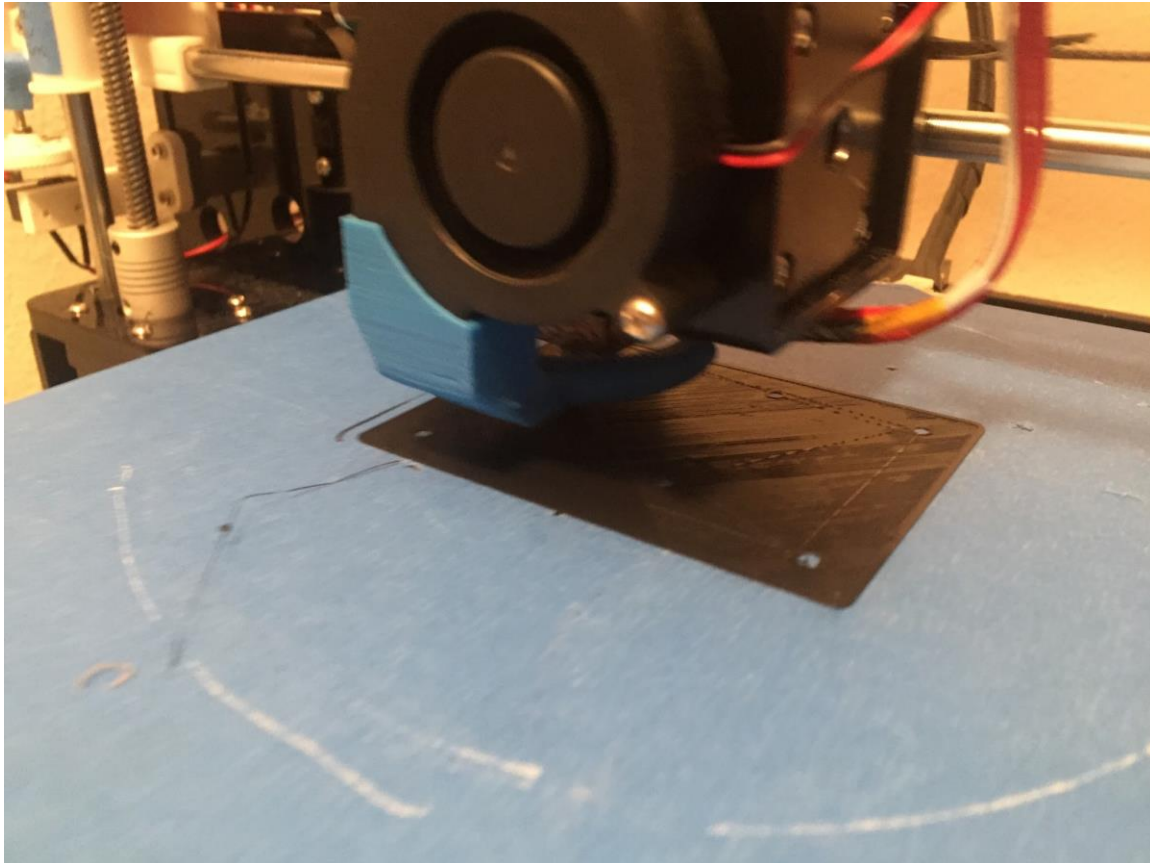

Figure 6.2: 3D printing the bottom plate for the device

6.3 PCB construction

To hold the electronic components, a PCB was required. This was designed using the schematic in DipTrace. The layout is shown in figure 6.3. Once the board was designed, it was exported to gerber files and sent to PCBWay in China for fabrication. The completed board is shown in figure 6.4. Once the board arrived, components were hand soldered to the board. The resulting board is shown in figure 6.5.

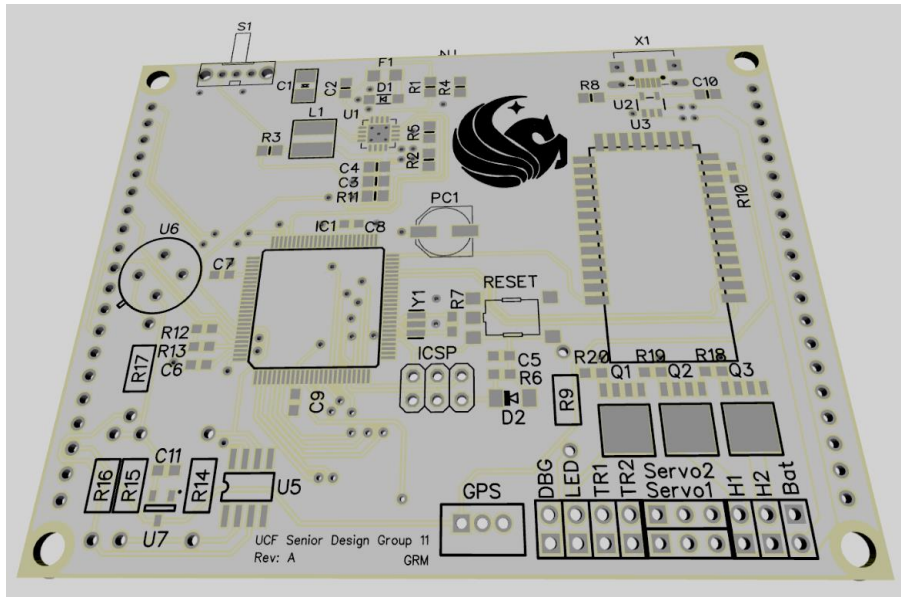

Figure 6.3: PCB layout as designed in DipTrace

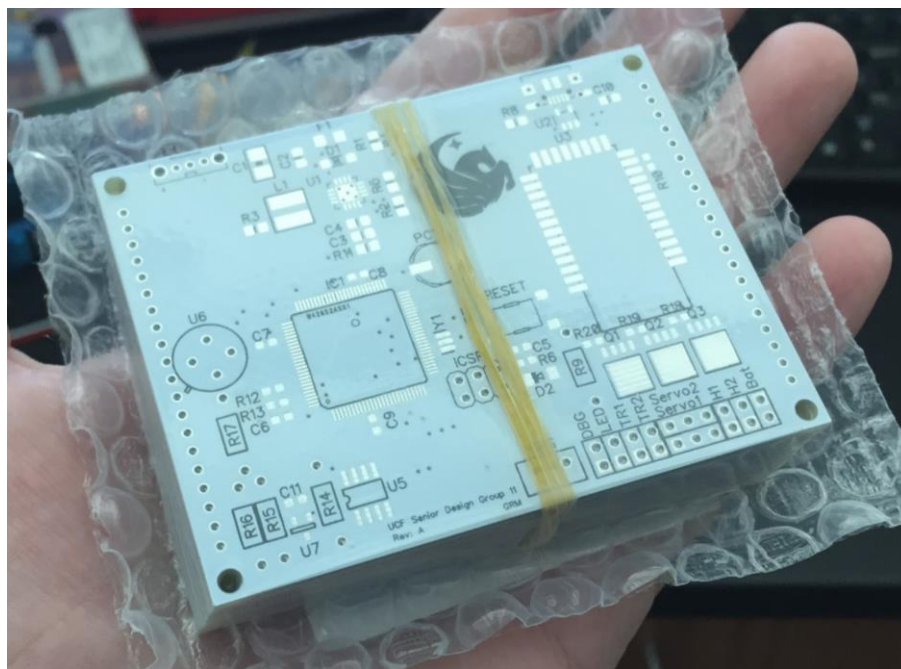

Figure 6.4: PCB after arriving from PCB Way

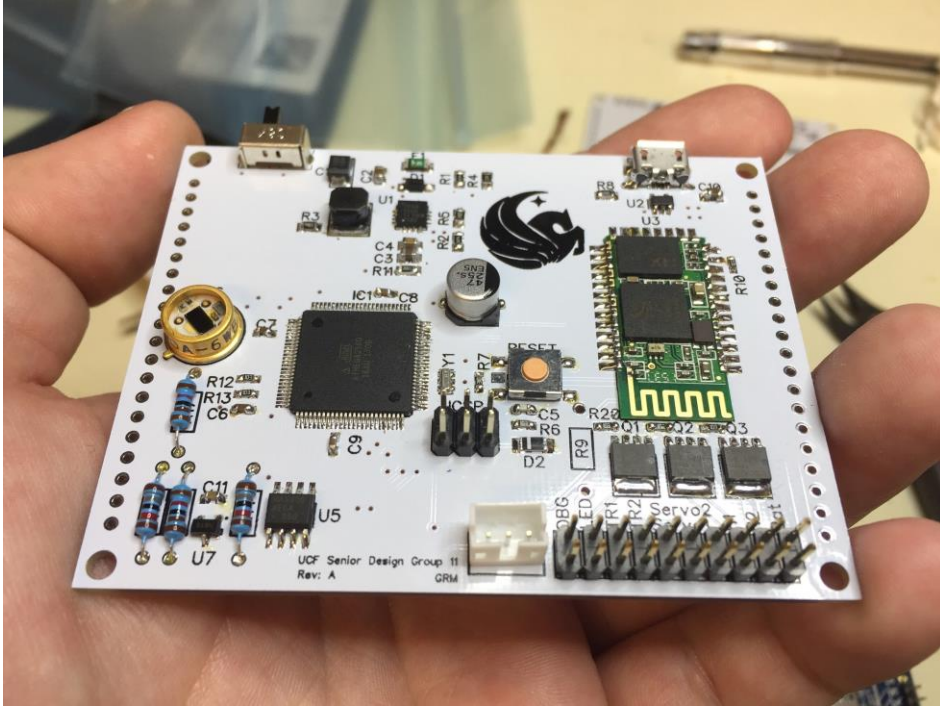

Figure 6.5: PCB after population and soldering of the electronic components.

7 Project Prototype Testing and Plan

To develop a functional system prototype, many tests must be performed. This section contains a summary of the various tests that will be performed to prove the functionality of the device. These tests include everything from thermal system tests to impact tests and PCR tests. The details for these test procedures as well as the results for several are included in this chapter.

7.1 Design and Prototype Testing

During the design process for this project, many tests must be performed in order to determine the effectiveness of the design and to provide insight for revisions. This section consists of many tests going to be used during the design process to help create the ideal final product.

7.1.1 Thermal Design Testing

Since thermal cycling is a critical part of the functionality of a PCR device, it is necessary to test the heating element's design. This is important to determine if the design will be sufficient. For testing, a simple setup is made which includes a heating element, complete with thermocouple and microcontroller for temperature control, and a modified PCR tube. The PCR tube had been modified by drilling a hole through the lid to allow for the insertion of a thermocouple. The leads of the thermocouple are long enough so that the thermocouple itself is near the bottom of the PCR tube, where the sample will be located. To simulate a sample, 20 microliters of water and 20 microliters of mineral were added to the PCR tube. This setup allows for the measurement of the temperature from directly inside of the PCR tube.

To test for the heating time, that is the period for which it takes the temperature of the sample to rise from 60 degrees C to 95 degrees C, the heating element is set to 120 degrees C and the PCR tube is touched to the heating element until the temperature inside is equal to 60 degrees C. Once this point has been reached, the tube is fully inserted into the heating element and the time taken for the tube to reach 95 is measured. A plot demonstrating this test is shown in Figure 7.1. A similar method is used for cooling where the temperature of the cooling element was held at 60 degrees and the sample was brought from 95 down to 60 by placing it into the cooling element.

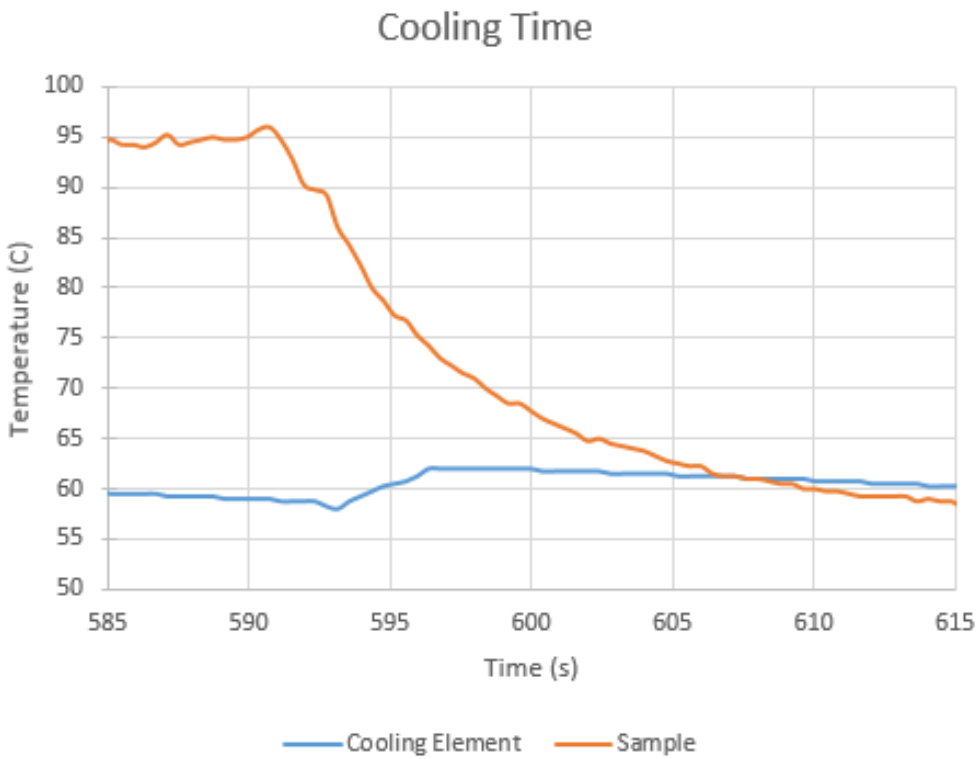
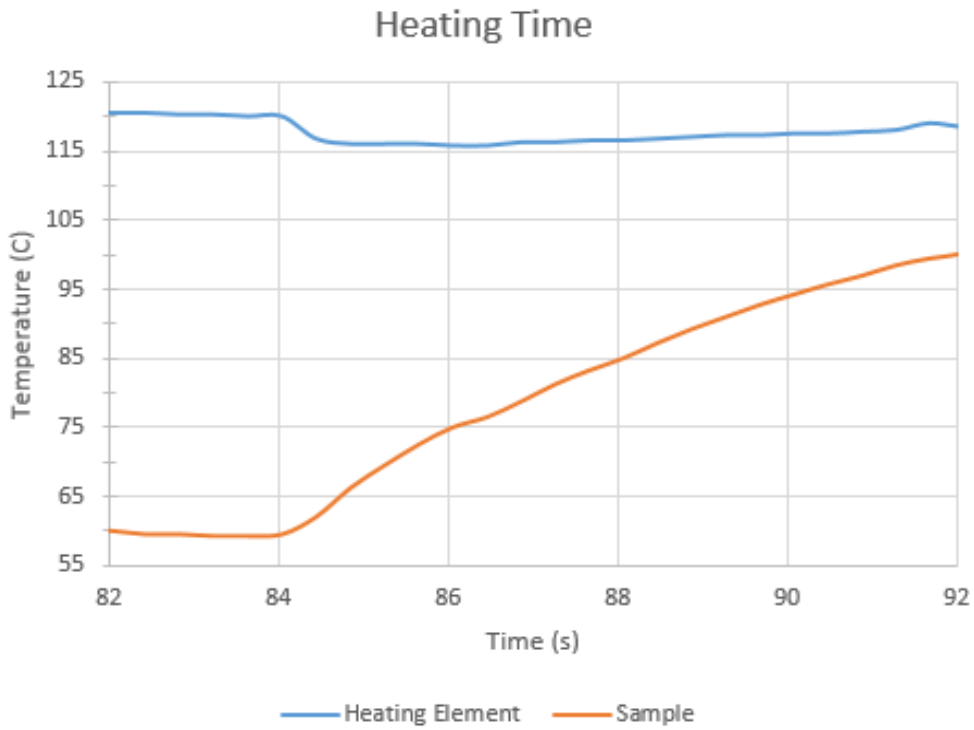

Figure 7.1: Heating and cooling test thermal plots used to determine heating and cooling time.

7.1.2 Impact Testing

To test our PCR machine design we will subject the machine to drops of various recorded heights onto a material which will simulate an outdoor setting, of various settings such as grass, gravel, dirt, and concrete. We will record the drop using a high speed camera so we may calculate the acceleration and see exact points of impact so that we may further reduce issues in the future. Ideally we would like to subject the PCR machine to a 1G, 2G, and 3G impact into these various ground representations. This is shown in Figure 7.2.

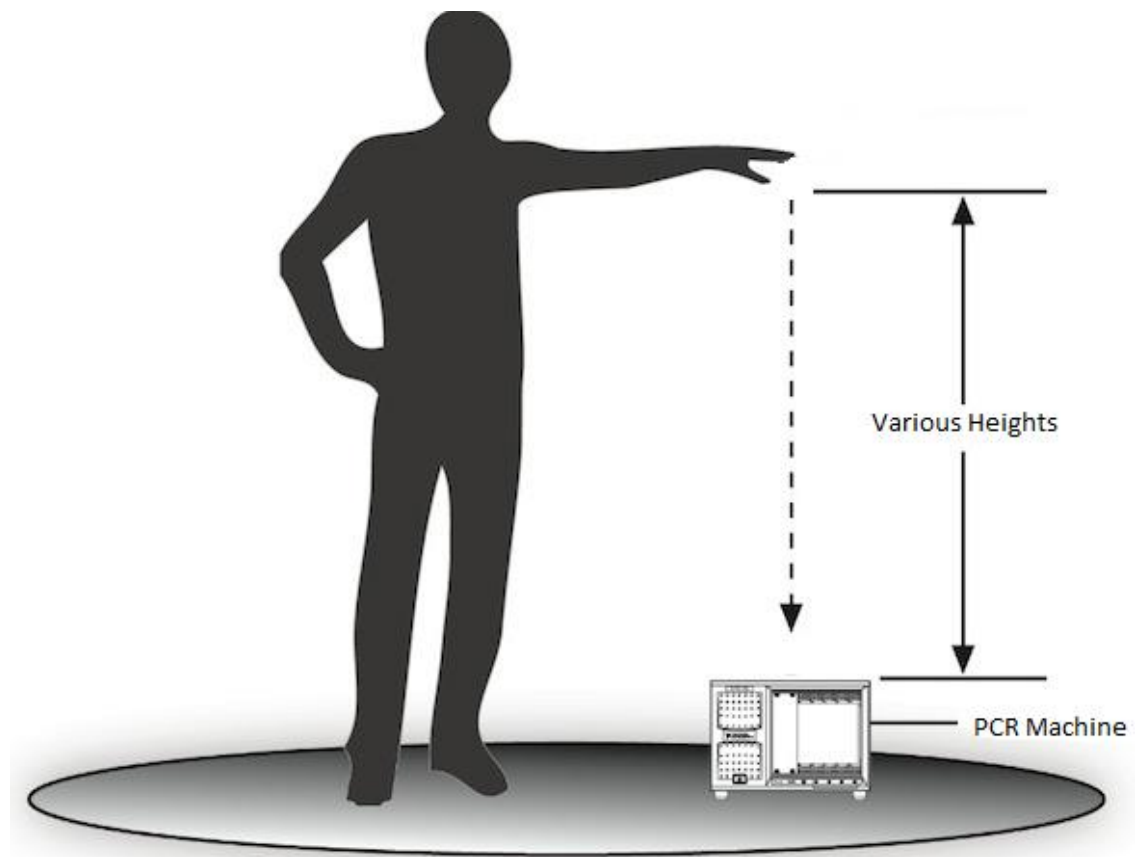

Figure 7.2: demonstration of a drop test.

7.2 Software Testing

Testing the software is an easy yet trivial process for our design. With all the components needed it may require additional testing along with the specific parts chosen when we integrate the whole design. The first step in the process though will be to simulate expected values and test a few different potential inputs from different devices. The software testing will include both microcontroller testing

and mobile application testing.

7.2.1 Simulated Testing

To begin, while developing the code simple debug situations on the functions will be used to test the efficiency and functionality of each block of code on a local simulator usually included in each software development kit. Simple inputs will be given to each block to ensure desired outputs followed by integrating the blocks to create a whole program. Testing the programs as a whole is more difficult, devising potential problem situations to stress the completeness of the program under every circumstance.

7.2.1.1 Microcontroller Software

To develop and test the code on the microcontroller we will use the standard arduino IDE to write and test our basic code blocks and functions. The arduino IDE is made specifically for the microcontroller we are most set and and is also compatible with a wide array of other microcontrollers so if anything went wrong or we found a better option and we needed to change out the physical hardware the studio will be able to still be compatible with our new decision. This IDE is also compatible cross-platform with Windows, Mac, and Linux and contains a large library to work with C and C++. We will test each feature first with simple numerical outputs and inputs to make sure calculations and reactions work right. There is also an interesting simulator for Arduino that supports a few less microcontrollers, Simulator for Arduino (which obviously works for mostly Arduino hardware). This simulator works great on windows PCs to simulate actual hardware hookups to further simulate the specifics of our code. It can support serial, Ethernet or SPI interfaces, servo control, SD card and more simulations which would be extremely useful for simulating an integrated test with all our components.

7.2.1.2 Mobile Application

Testing our mobile application will be a bit more difficult until a more physical testing, but until then MIT app inventor does provide a virtual simulator of a typical android phone. Development will be very similar with hard coded values given to test each block of code. MIT app inventor will be used alongside the android app studio to fine tune and develop the code and test it on the virtual simulator. Connection with our PCR machine will be almost impossible to simulate once the entire program is compiled together so simple expected values will just be given as input but exact signals will be expected as output (mostly as wireless feedback).

7.2.2 Physical Testing

Once each program is working well we will need to test it with the actual components. This step will be more imperative for the microcontroller and may take more work but is mostly trivial. Especially if we use the Simulator for arduino to test it with our potential components this step shouldn't run into many problems. Most problems will probably occur with broken parts or different compatibility which doesn't require much code changing, possibly just a single line or small block to accommodate the part.

Testing the microcontroller will include a simple test of each component with a simple feedback first to ensure the code is working properly with the component. Integration of each part will begin slowly ensuring stability and reliability with each part. Once together many situations will be devised to stress test the program and ensure every component works well under the circumstances.

Testing the mobile application with the physical product will most likely be one of the last things done in our project. First, downloading the program onto an actual Android is pretty simple. Because there isn't much difference between the actual android and the virtual simulator, issues are not likely to arise. The completed PCR machine will then be able to send the messages wirelessly to an android device downloaded with the program and tested together. Each possible function of communication between the two devices will be tested to ensure stability as well. Testing the PCR machine while connected will also probably show problems with the microcontroller's code, making this most likely the most frustrating point of testing. Changes to either's code can be simply uploaded quickly, and with the Android studio in real time to quickly test and debug the programs.

7.3 Final Device Testing Plan and Goals

Once the device is complete, it is important to test the final form of the project to ensure its functionality and compliance with the initial design requirements. This section covers tests that will be used for this purpose.

7.3.1 PCR Testing

The overall goal of the project is to design and build a device which is able to perform quantitative PCR. In order to be certain that the qPCR device is able to detect the presence of a virus, tests will need to be performed on samples which contain a known virus quantity, as well as be able to differentiate positive samples and controls. Traditionally, tests of real time PCR machines use test runs of multiple virus concentrations in order to create a plot of multiple concentrations

on the same graph. Usually, the difference in virus concentration between these tests is a factor of 10. Because of the characteristic of PCR where the number of DNA sample doubles with each cycle, the number of DNA molecules in the sample with respect to a given number of cycles n is:

$$\#DNA_{final} = \#DNA_{initial} * 2^n$$

So if the same final point is referenced, the equation can be rewritten to solve for the cycle number where the final DNA concentration is crossed:

$$n = \log_2(\#DNA_{final} / \#DNA_{initial})$$

Thus, if the final concentration is the same value for two experiments and the initial concentration is an order of magnitude, or ten times more dilute, then the cycle where the threshold is crossed will shift by ~3 cycles.

$$n = \log_2(1 / 0.1) = 3.01$$

To further illustrate what is expected to see, the following plot is provided by Dr. Kim's lab. These tests were run using three different virus concentrations of 2×10^7 , 2×10^6 , and 2×10^5 ; as well as a control, containing no virus. It is clear what it meant by this shift of three cycles by looking at the graphical representation in Figure 7.3. Notice that each curve with the exception of the control, is approximately three cycles to the right of the one before it. This indicates that the concentration for each run is 10 times more dilute than the one before it.

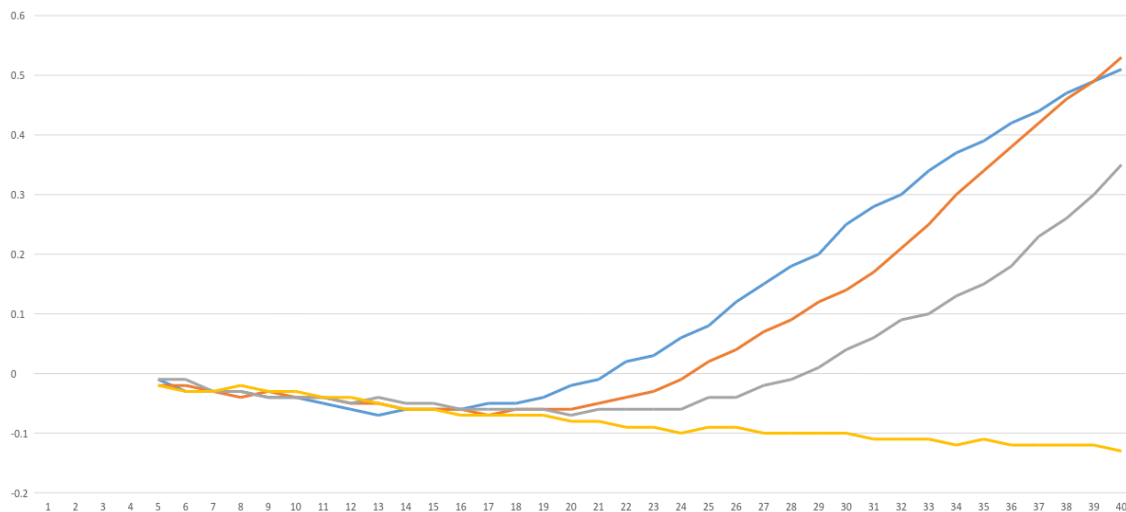

Figure 7.3: Experimental data that should be replicated by new PCR machine. The four curves, blue, orange, gray, and yellow, are the samples containing 10^7 , 10^6 , 10^5 , and the control respectively.

7.3.2 Sample Preparation

Preparation of samples to use in the device is of the utmost importance. The details of the samples are as follows. There are five reagents which must be mixed and placed in the PCR tube as well as the virus-containing sample in order to perform a test. These reagents are, in order of largest to smallest volume, mineral oil, molecular biology grade DNA/RNA free purified water, the RT-PCR mix, polymerase, and the TaqMan solution. The mineral oil serves to keep the evaporation of the other reagents to a minimum so that the evaporation does not interfere with the optics, thus helping to avoid false measurements. Additionally, mineral oil is inert and will not interfere with any of the microbiology that will be taking place in the sample. Water serves as the main solvent for the other reagents, allowing a solution for all of the reagents to mix thoroughly. The important detail is that the water must be supplied absolutely pure and suitable for molecular biology. If non-suitable water is used, the chance of recording false positives increases dramatically. This will occur because most water contains some form of living organisms within it, and if it does not, it almost certainly contains trace amounts of unknown RNA and DNA which could interfere with the amplification process of PCR, spoiling an experiment. The RT-PCR mix contains chemicals necessary for the PCR process to take place, namely the nucleotides which will be used during the amplification process and other reaction stabilizing chemicals. Polymerase is the enzyme for which polymerase chain reaction is named. It is the main component required for assembling together nucleotides into DNA. This is an enzyme found in all living things which allows for the DNA replication process to occur and is used in PCR to amplify the quantity of DNA. TaqMan is a solution containing the primer which is designed to bond with and only with the mouse SOX2 gene. It also contains the fluorescent probes which will be the means for the detection of the quantity of target DNA. Finally, and perhaps the most important element, is the target DNA itself. This comes supplied in a concentrated solution of a known value. In this case, the concentration is specified as 2×10^7 virus particles per milliliter. The volumes of each reagent are shown in Table 7.1.

Element	Required Volume (μ l)	Details
Mineral Oil	20	Prevents evaporation
Molecular Biology Grade Water	6	Extremely pure, DNA and RNA free
RT-PCR Mix	10	Required chemistry for PCR
Polymerase Solution	1	Critical component of DNA amplification

TaqMan Solution	1	Contains primer and probes
Target Virus	2	Contains target DNA
Total	40	Volume of reaction is 40 ml

Table 7.1: The elements of a PCR sample and their required volumes.

One important note is that the quantities of each element required in the reaction mixture is extremely important. Because of this requirement, great care must be taken by the preparer of the sample to be absolutely certain that the correct amount is included in the mixture. If mixtures are slightly off from the nominal values, the reaction could fail in numerous ways, and would have to be rerun. The quantities chosen above have been carefully chosen by Dr. Kim's lab by experimentation and recommendation from the manufacturers of the reagents. In addition to the reagents listed above, a number of tools and materials are needed. The most important tool for this work is a biosafety cabinet. A biosafety cabinet is an engineering control that is designed to keep any airborne biological particles contained. This functions by a controller airflow and extremely fine HEPA filters. Since a virus will be used it is important that any containers holding the virus are only opened within the biosafety cabinet. The biosafety cabinet required for the sample preparation is shown in figure 7.4. The other important materials for safety are the elements of personal protective equipment (PPE), in this case the sample preparer will require closed-toed shoes, long pants, a lab coat, safety glasses, and nitrile exam gloves. They will also require 70% ethanol in a spray bottle, used for cleaning; PCR tubes, for holding the sample; pipettes, for accurate measurement and placement of the various reagents; an ice bucket, for keeping reagents chilled until ready for use; and a black box, used for protecting the reagents and samples from excessive light which can lead to photobleaching.



Figure 7.4: A biosafety cabinet at the Burnett School of Biomedical Sciences.

7.3.2.1 Sample Preparation Procedure

The sample preparation procedure is as follows:

1. Retrieve all chemistry and place all reagents with the exception of mineral oil in a light proof container and in ice.
2. Put on labcoat, safety glasses, and nitrile exam gloves.
3. Thoroughly clean the biosafety cabinet and pipettes using 70% ethanol spray.
4. Place pipettes, pipette tips, chilled reagents in the black box, and PCR tubes in the biosafety cabinet.
5. Begin thawing the water using the heat from gloved hand, then pipette 6 microliters into an empty PCR tube using the 20 microliter pipette. Return the water to the black box.
6. Begin thawing the RT-PCR mix, while doing so, set the 20 microliter pipette to 10 microliters. Once thawed, use the vortex mixer to ensure that the RT-PCR mix is thoroughly mixed. When ready, pipette 10 microliters of RT-PCR mix into the PCR tube. Return the mix into the black box.
7. Begin thawing the polymerase and set the 2 microliter pipette to 1 microliter. Mix the polymerase using the vortex mixer and pipette into the PCR tube. Return polymerase to the black box.
8. Begin thawing the TaqMan solution. Mix with the vortex mixer. Use the 2 microliter pipette still set to 1 microliter to pipette into the PCR tube. Return Taqman to the black box.
9. Begin thawing the virus sample. While thawing, set the 2 microliter pipette back to 2 microliters. Mix with the vortex mixer, and pipette into the PCR tube. Unused virus should be placed in the biowaste container and be properly disposed of.
10. The tube now contains all of the biological elements. To ensure that the mixture is ideal by mixing with the vortex mixer. If there are any liquids on the walls of the PCR tube, or air bubbles, use the centrifuge to settle the contents to the bottom.
11. Now use the 20 microliter pipette and pipette 20 microliters of mineral oil

on top of the solution. This should appear as a film of oil floating on top of the solution. It is important to avoid shaking the PCR tube at this stage to avoid the mixture of mineral oil with the remaining solution. If necessary, the PCR tube may be centrifuged to separate the oil and water. However, care should be taken to not over centrifuge the tube, this could cause the reagents to settle out of the water and no longer be properly mixed.

12. Return the unused reagents to the freezer and thoroughly clean the biosafety cabinet and pipettes using 70% ethanol.

13. The sample is now ready to be placed into the PCR machine to run PCR.

8 Administrative Content

One of the most important components to this project is the administrative work. Without this, a project cannot operate smoothly. To remedy this, we have assembled a list of milestones and developed a timeline to ensure that our project remains on schedule. This section contains the timeline and milestones we have created as well as a summary of the costs which we expect to incur and details of our sponsorship.

8.1 Timeline and Milestones

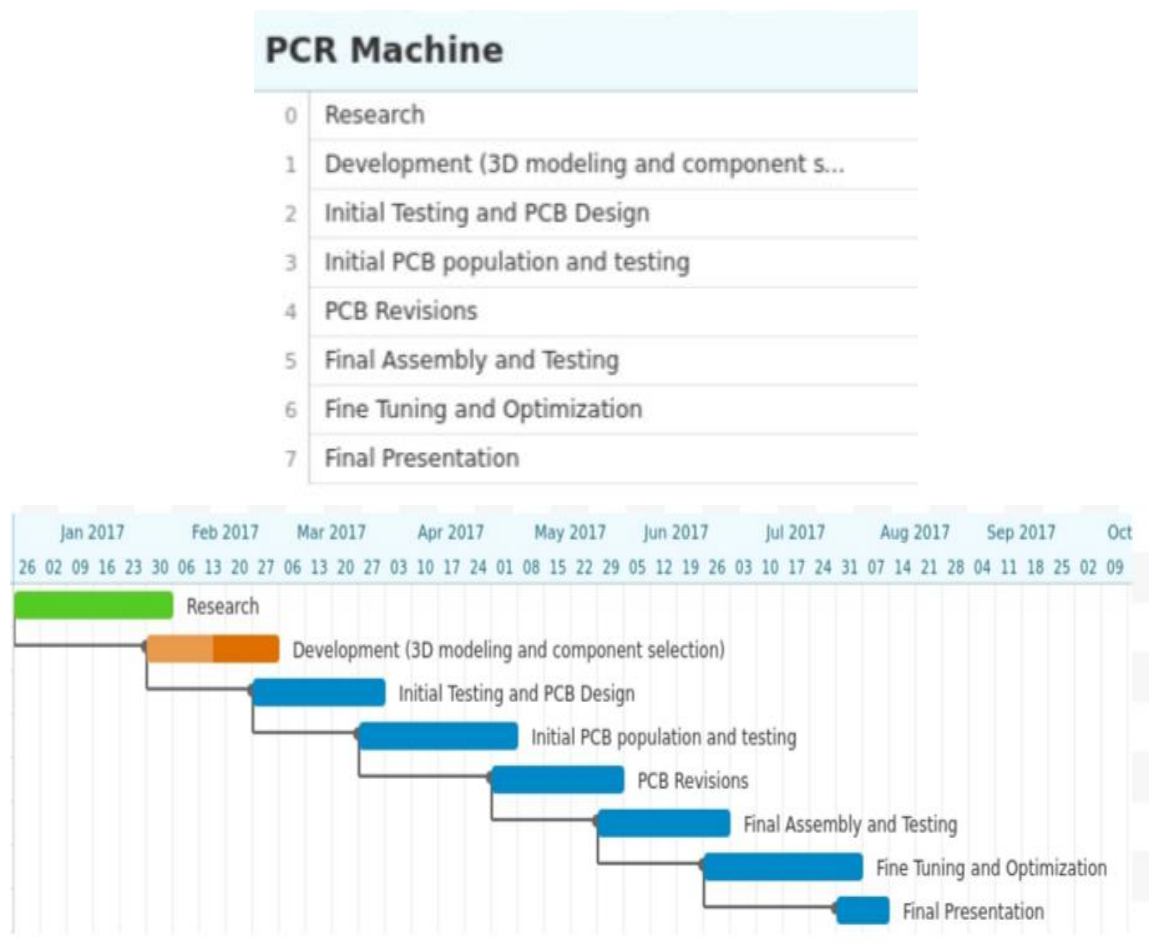

Figure 8.1: milestones and timeline for the PCR machine project.

8.2 Budget and Finance Discussion

Item	Budget	Price Spent	Suppliers
Display	\$50	\$29.95	Adafruit
Electronic Components	\$200	\$167.71	DigiKey
Bluetooth Module	\$20	\$7.99	Amazon
GPS Module	\$20	\$19.95	Amazon
Batteries	\$20	\$11.90	BatterySpace
Mechanical Components	\$100	\$82.47	Amazon, Omega Optical
PCB	\$60	\$28.00	PCB Way
Total	\$500	\$347.97	

Table 8.1: showing costs that represent the estimated cost of the machine.

The above table lists several items already selected by the group's initial research and gives a reasonable reflection of the proposed cost of the device. According to the totals, the overall device is expected to cost well under 500 dollars. This price point will surely make an improvement to the low cost range of devices within the medical diagnostic community.

8.3 Sponsorship

Through the course of our project we will be working with a UCF faculty member. Dr. Brian N. Kim will be sponsoring our efforts. Dr. Kim's lab specializes in the field of bioelectronics which includes diagnostic devices similar to the one being proposed by the group. Additionally, Dr. Kim's lab is located at the Burnett School of Biomedical Sciences Lake Nona Campus, which will allow the group to perform medical experiments in the lab in order to confirm the functionality of the device.

Without access to a biosafety lab, these experiments would not be able to be performed. Dr. Kim is appointed by both the College of Engineering and Computer Science and the College of Medicine.

Appendix

Sources:

- 1) "IP Rating Chart." DSMT.com. Accessed March 2, 2017.
<http://www.dsmt.com/resources/ip-rating-chart/>.
- 2) "FR-4." Wikipedia. March 30, 2017. Accessed March 14, 2017.
<https://en.wikipedia.org/wiki/FR-4>.
- 3) Arduino - ArduinoBoardMega2560. Accessed April 11, 2017.
<https://www.arduino.cc/en/Main/arduinoBoardMega2560>.
- 4) "PSMN0R9-25YLC,115 Nexperia | Mouser." Mouser Electronics. Accessed February 7, 2017.
<http://www.mouser.com/Search/ProductDetail.aspx?R=PSMN0R9-25YLC%2C115virtualkey66840000virtualkey771-PSMN0R925YLC115>.
- 5) "SM103J1K-TR US Sensor | Mouser." Mouser Electronics. Accessed April 11, 2017.
<http://www.mouser.com/Search/ProductDetail.aspx?R=SM103J1K-TRvirtualkey68030000virtualkey803-SM103J1K-TR>.
- 6) "Thermistor." Wikipedia. April 10, 2017. Accessed March 20, 2017.
<https://en.wikipedia.org/wiki/Thermistor>.
- 7) "Thermistor." Overview | Thermistor | Adafruit Learning System. Accessed March 15, 2017. <https://learn.adafruit.com/thermistor?view=all>.
- 8) "CC2640 (ACTIVE)." CC2640 SimpleLink ultra-low power wireless MCU for Bluetooth low energy | TI.com. Accessed April 3, 2017.
<http://www.ti.com/product/CC2640>.
- 9) "ATmega2560." Microchip Technology Inc. Accessed March 30, 2017.
<http://www.microchip.com/wwwproducts/en/ATmega2560>.
- 10) "Meet Android Studio." Android Developers. Accessed April 11, 2017.
<https://developer.android.com/studio/intro/index.html>.
- 11) "DOWNLOAD." Arduino Playground - PIDLibrary. Accessed March 12, 2017. <http://playground.arduino.cc/Code/PIDLibrary>.
- 12) "520AF18." Omega Optical: Light You Need. Accessed April 16, 2017.
<http://www.omegafilters.com/520af18.html>.
- 13) "Basics of UART Communication." Circuit Basics. April 11, 2017. Accessed April 18, 2017. <http://www.circuitbasics.com/basics-uart-communication/>.
- 14) "Research Fellow at University of Massachusetts Medical School, Worcester, MA." MiniPCR. Accessed April 6, 2017.
<http://www.minipcr.com/products/minipcr/>.
- 15) Continuous flow real-time PCR device using multi-channel fluorescence excitation and detection. By Andrew C. Hatch, et. al.
- 16) A portable, shock-proof, surface-heated droplet PCR system for Escherichia coli detection. By Scott V. Angus, et. al.